

# 1000KG Auto Solar Slide Sliding Gate Opener Automatic w 4m Rail

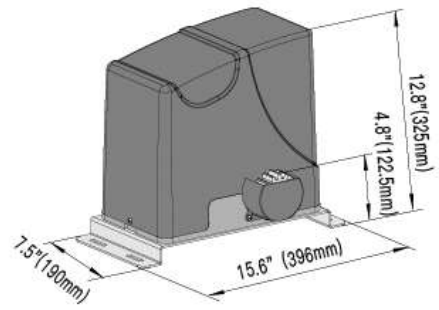

Specifications	
	HUH-1P
Power supply:	230V/50Hz
Motor voltage:	24VDC
Absorbed power:	350W
Gate moving speed:	20 cm/second
Max gate weight:	1000KGS
Max torque:	24Nm
Environmental conditions:	From -15°C to +40°C
Protection class:	IP44
Dimensions:	39.6×19×31.5 CM

