

10 min

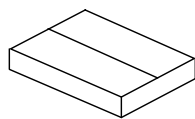

x2



x1

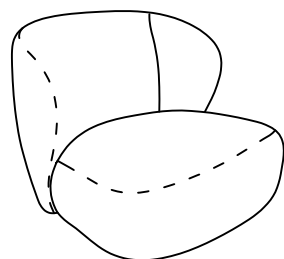

A*1

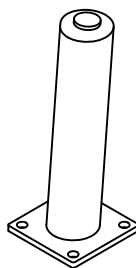

B*4

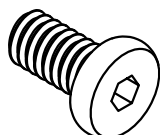

C*16

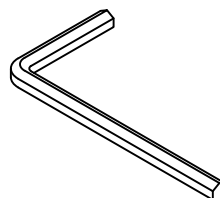

D*1

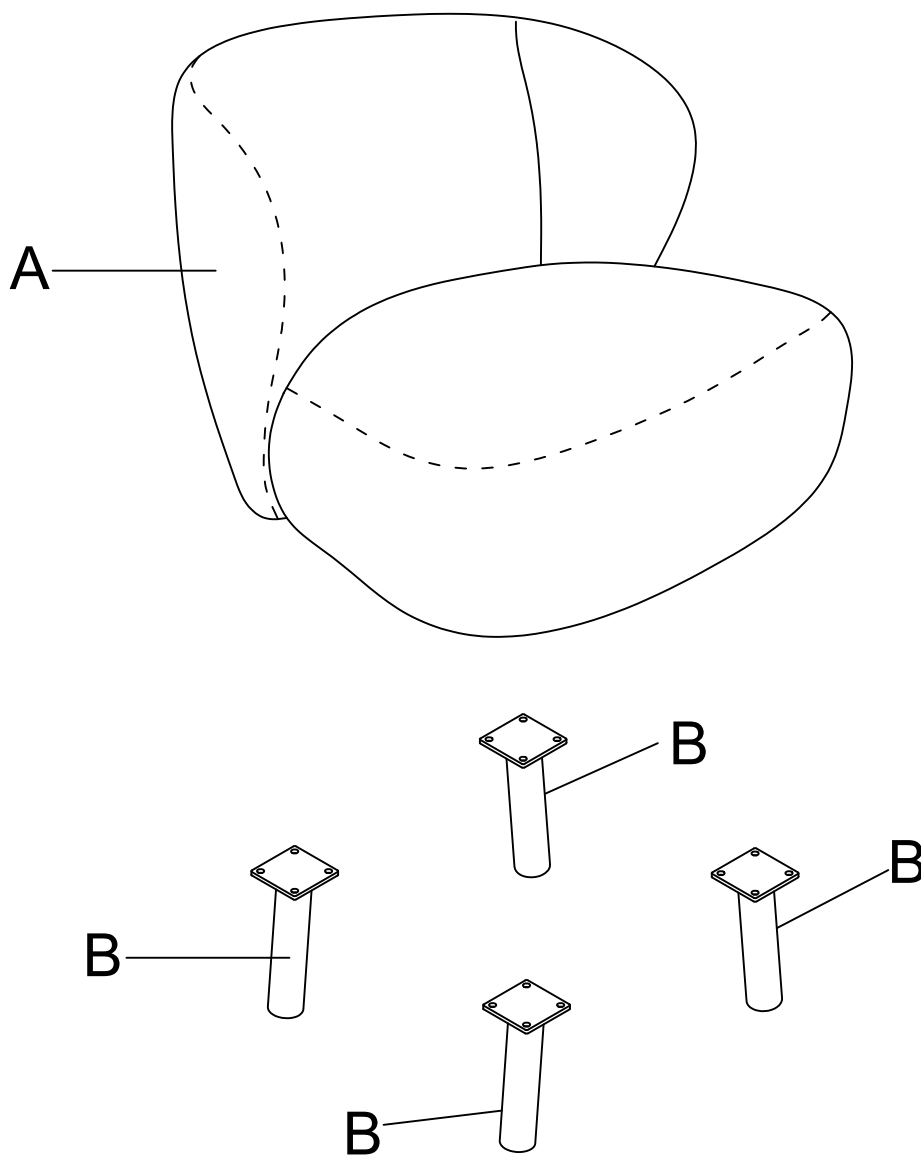

①

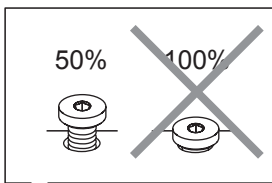
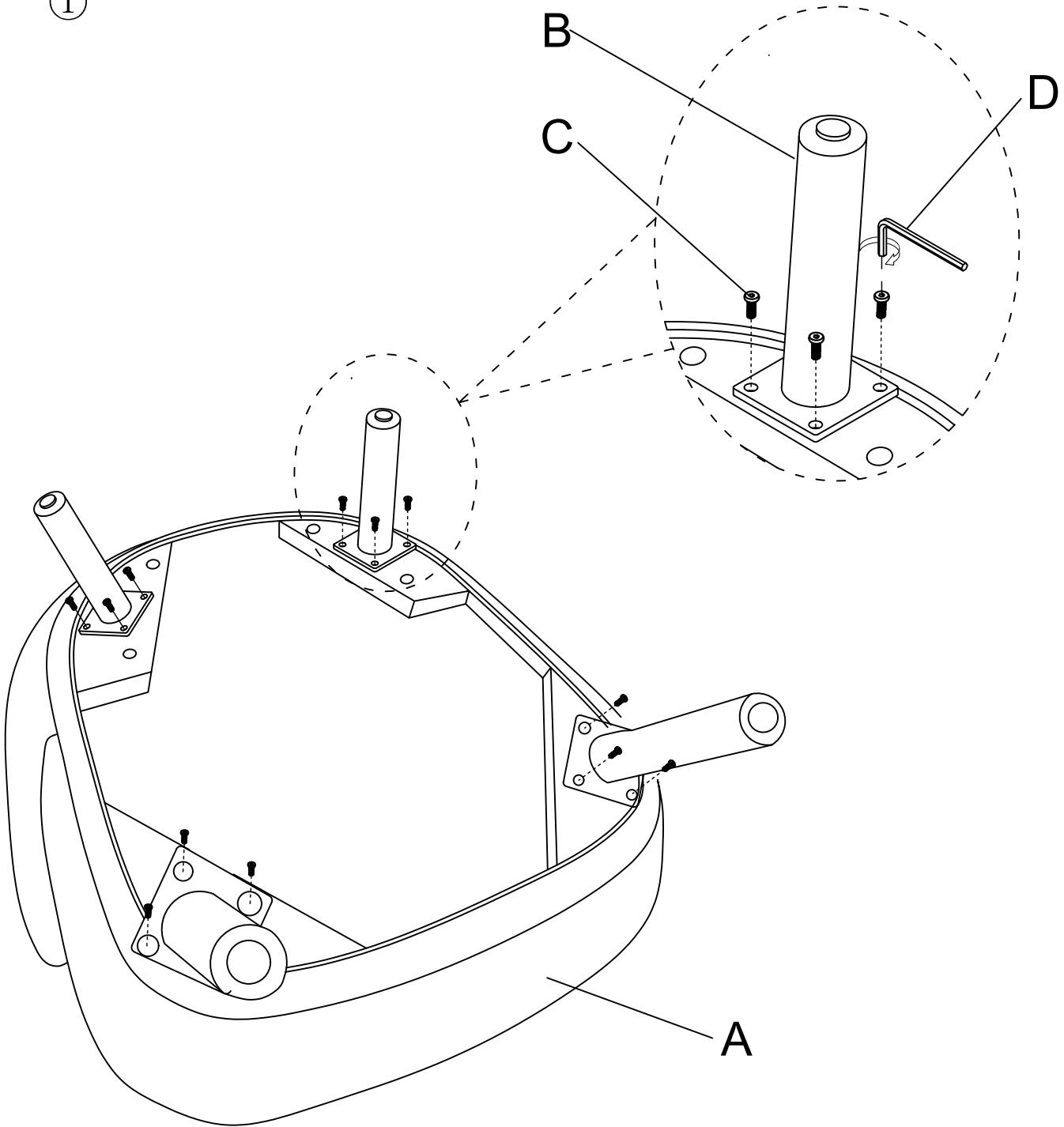

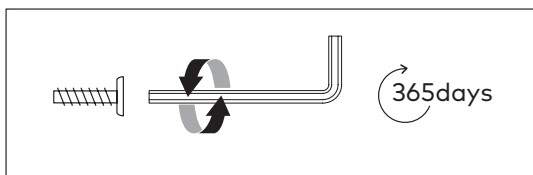
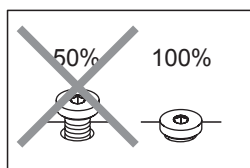
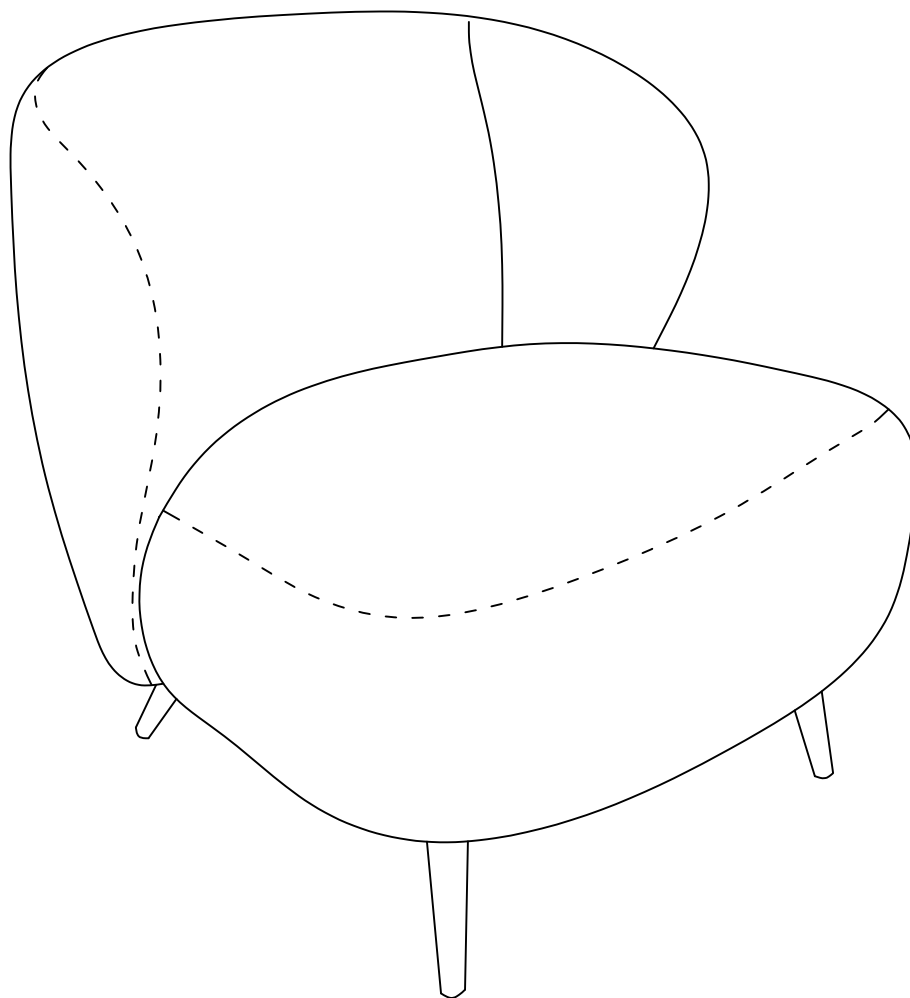

THAT'S ALL FOLKS

Share your style!

