

ASSEMBLY INSTRUCTION

EXECUTIVE TABLE WITH FIXED SIDE CABINET

ITEM CODE: W601-L

This instruction suitable for 220*193*76cm

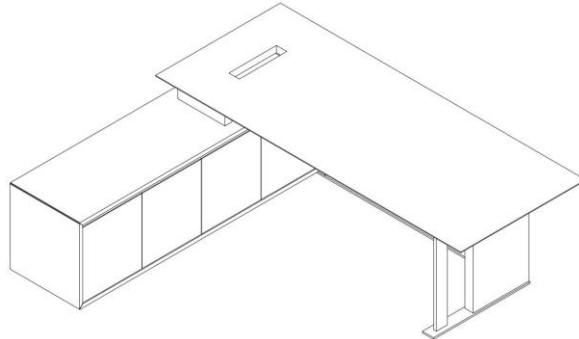

PRE-ASSEMBLY PREPARATION

Before you start:

1. Choose a clean & spacious assembly area, avoid hard surfaces that may damage the product.
2. Take care when lifting product. It should be assembled as near as possible to the point of use.
3. Ensure that you have all required contents for complete assembly.
4. Always read the assembly instructions carefully before beginning assembly.
5. Keep all hardware parts and packing material out of children.
6. Do not over tighten the screws and bolts as this may damage threads.
7. It would take 2 hrs and 30 minutes when 2 people required.
8. Additional Tools required is screw-driver.



Warning

Serious or fatal injuries may occur from furniture toppling over.

For security, please follow the below recommendations:

- Never allow children to climb on or hang off of any part of this product
- Unless specifically designed to accommodate, do not set TVs or other heavy objects on top of this product

If this product has drawers:

- Place the heaviest items in lowest drawers
- Do not open more than 1 drawer at a time as this may cause the product to become unbalanced
- Do not tamper with or remove any drawer interlocking/sliding system
- Please use this product with caution
- This is a permanent label. Do not attempt to remove!







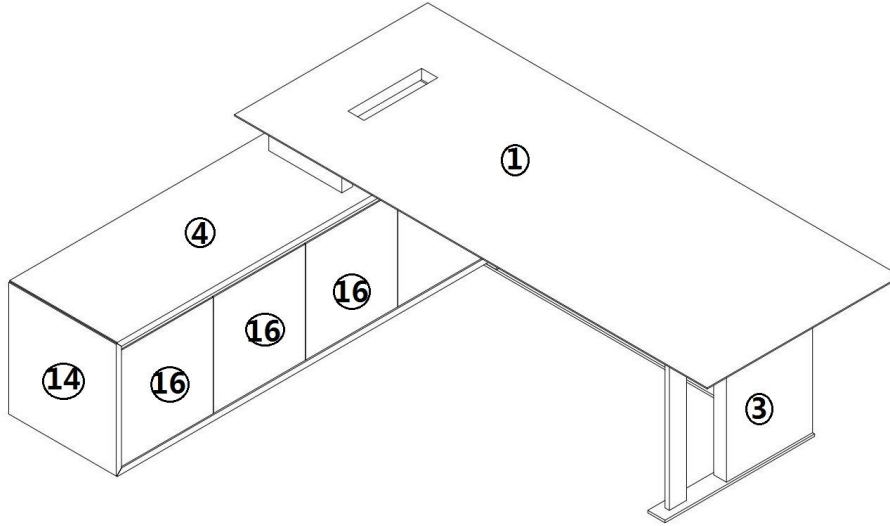









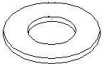

PARTS LIST

Upon receiving the furniture, please check product size, carton quantity and the direction of the side cabinet's location is correct prior to assembly.

The W601 executive table set should be packaged in 6 cartons. The shipping mark to be show on 6-1, 6-2, 6-3, 6-4, 6-5 & 6-6.



Carton No.	Panel No.	Panel Size (CM)	Qty		Carton No.	Panel No.	Panel Size (CM)	Qty
6-1	1	220*90*4.5	1		6-3	10	172*5*1.5	1
6-2	2	68*40*6	1		6-4	11	59*10*5	1
6-2	3	68*42*6	1		6-4	12	34*10*5	1
6-3	4	176*50*2.5	1		6-4	13	85.1*46*1.5	2
6-3	5	176*50*2.5	1		6-5	14	53*50*2.5	2
6-3	6	172*49*1.5	1		6-5	15	49*46.4*1.5	1
6-3	7	156.6*6*1.5	2		6-5	16	46.8*42.7*1.5	4
6-3	8	27*6*1.5	4		6-6	T Metal	182*69.6*8*1	2
6-3	9	108.8*40*1.5	1					

Accessories list (put in Ctn No.6-4)				
No.	Name	Size(mm)	QTY	Drawing
A	3 in 1 minifix- Bolt (Red)	40	43	
	3 in 1 minifix-Cam	Ø15	59	
B	Hexagon Spanner		1	
C	Hinge-Half overlay		4	
D	Hinge-Inset		4	
E	Connecting Bolt	6*10	46	
F	Straight Bolt	6*150	4	
G	Screw Nut	6*4	4	
H	Gasket	6*15	4	
I	Stainless steel tube	68*8*2	1	
J	Connecting Bolt	6*20	6	
K	Double folding rod	5.3*84	8	
L	Short Screw	3.5*14	48	
O	Shelf support pin	5	8	
p	Hex socket cap screw	6*30	2	
Q	Hex socket cap screw	6*50	18	
R	Hex socket cap screw	6*25	4	
S	Stainless steel tube	68*3*1.5	17	

GENERAL ASSMEBLY DETAILS:

How to use 3 in 1 Mini-Fix Cam & Pins (Accessory A in Red) Fasteners

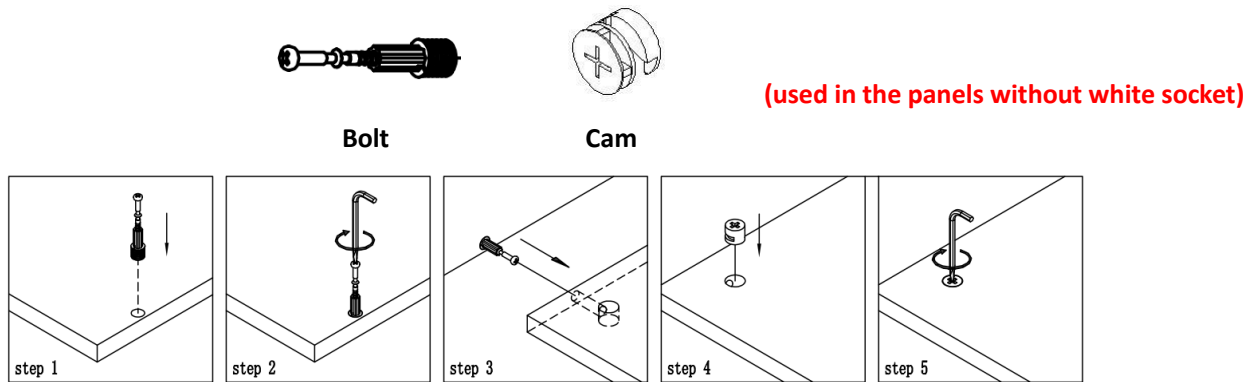

Cam lock fasteners are used to join two pcs boards together.

1. Using a screw driver or cordless drill, do not over tighten Bolts.
2. Use a flathead screwdriver to turn and tighten the Cam lock in a clockwise direction until the head of the pin is tightly secured. **DO NOT USE A CORDLESS DRILL**

How to use 3 in 1 Mini-Fix Cam & Pins (Accessory A in Black) Fasteners



Cam lock fasteners are used to join two pcs boards together.

3. All white sockets have been pre-installed in the boards to secure the bolts
4. Using a screw driver or cordless drill, do not over tighten Bolts.
5. Use a flathead screwdriver to turn and tighten the Cam lock in a clockwise direction until the head of the pin is tightly secured. **DO NOT USE A CORDLES DRILL**

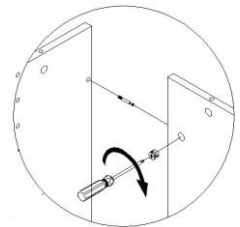

How to separate drawer sliders?

The drawer slide I1 & I2 may be connected.

Carefully pull out slide part I2 and press the plastic clip/lever to unlock to fully separate the two parts of the runner.

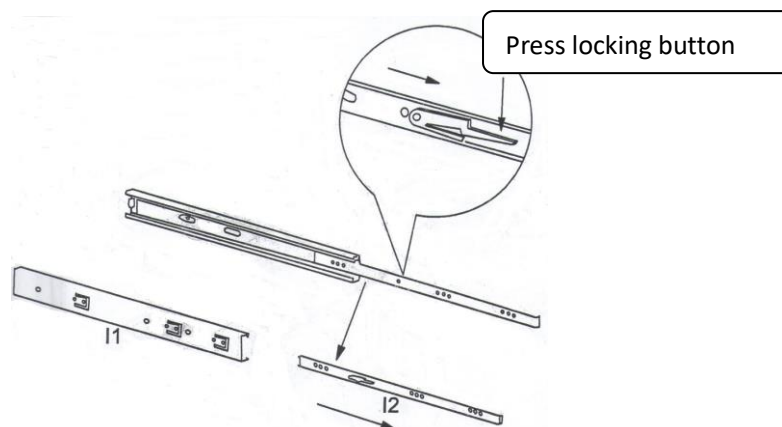

START TO ASSEMBLE

Step 1: Assemble side return

(1) Open 6-3 and 6-5 cartons. Connect Bottom Panel No.5 & Back Panel No.6 & Middle Panel No.15 by accessories A.

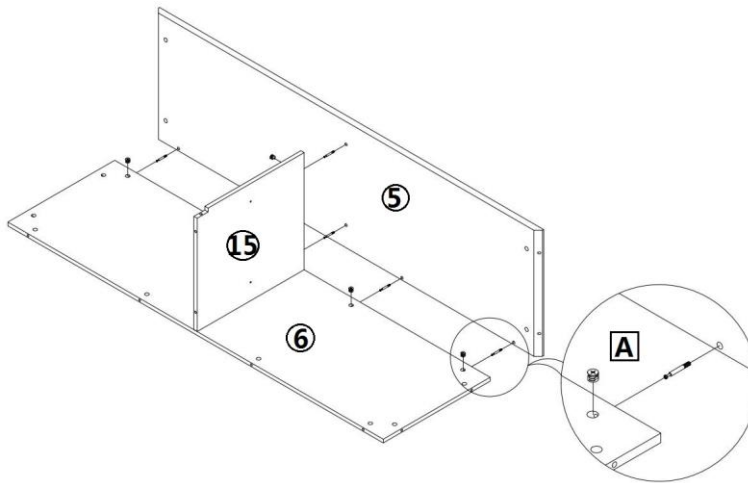

(2) Same operation as last step. Connect Top Panel No.4 & Back Panel No.6 & Middle Panel No.15 by accessories A.

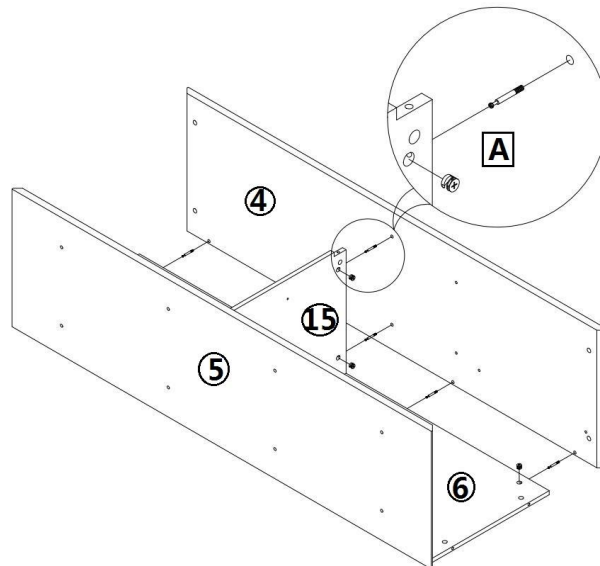

(3) Connect Panel No.10 & Middle Panel No.15 by accessories A.

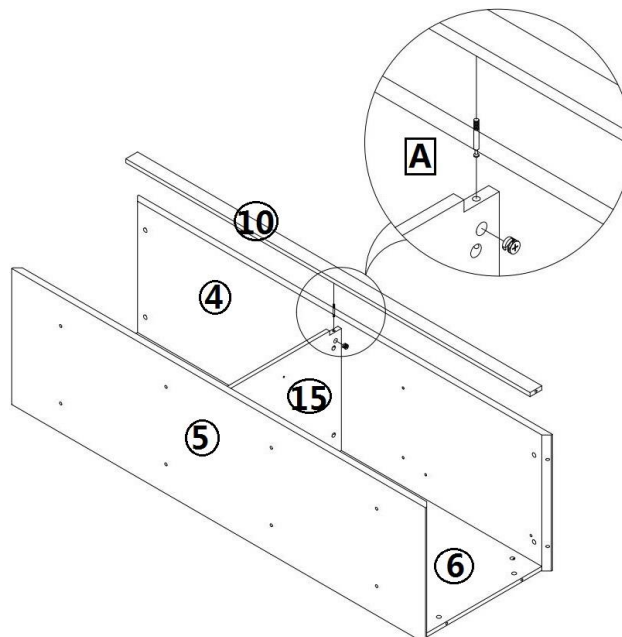

(4) Connect Side Panel No.14 with Top Panel No.4 & Bottom Panel No.5 by accessories K.

Connect Side Panel No.14 with Panel No.10 by accessories A. And lock the accessories A cam.

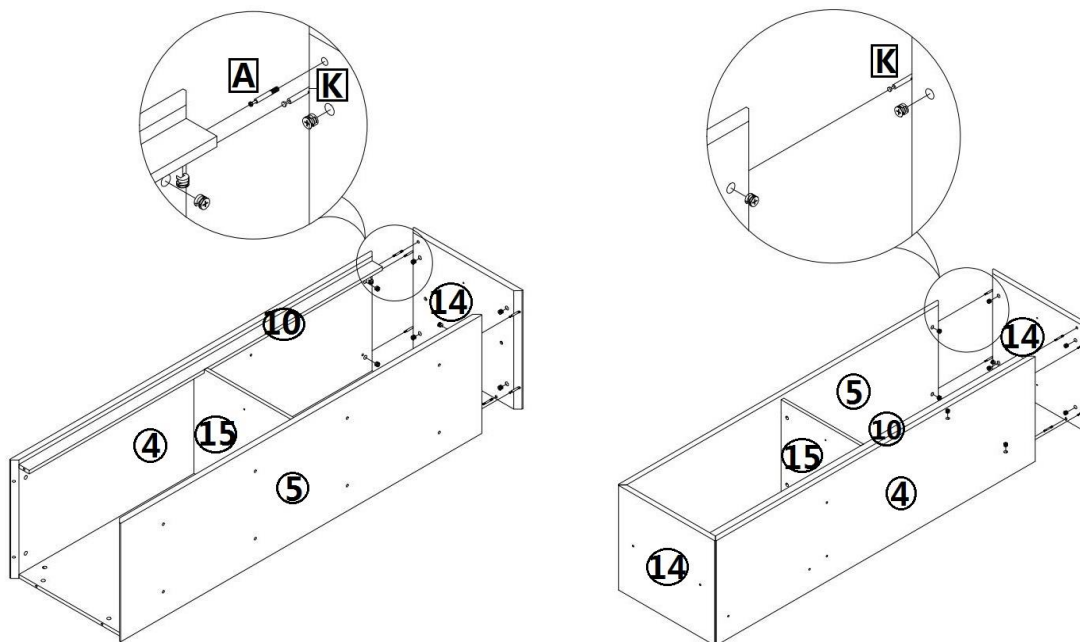

(5) Assemble the support frame under the side return. Connect Panel No 7, 8 by accessories A.

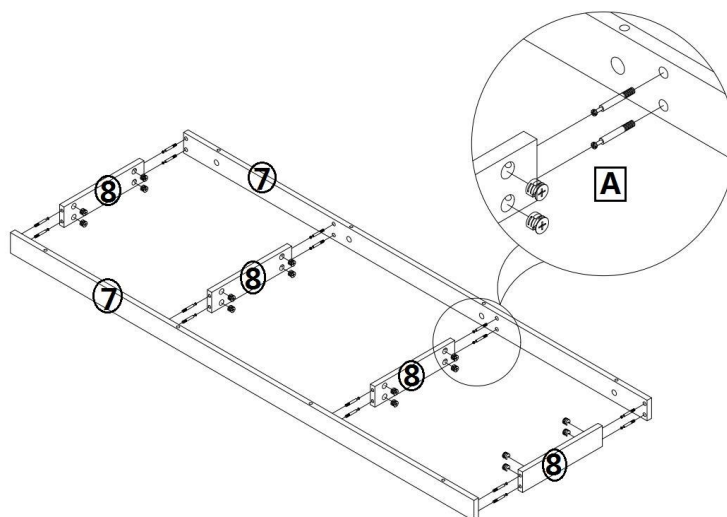

(6) Connect the support frame with the side return by connecting Panel No 7,8 & Bottom Panel No.5 by accessories A.

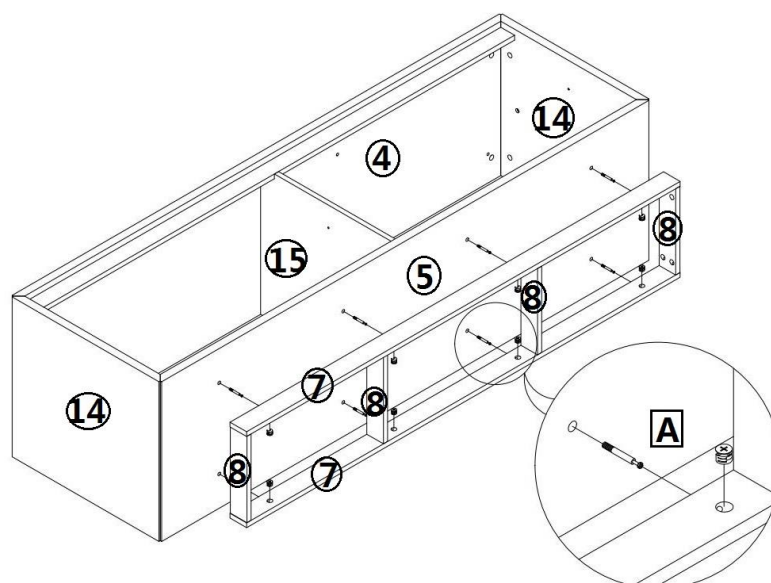

Step 2: Assemble the Leg panel, front panel and stainless steel tube

(1) Open 6-2 and 6-6 cartons. Tighten stainless steel tube I & S with L-shaped stainless steel with E (6*10mm) connecting bolt. Connect Panel No.2 & 3 with L-shaped stainless steel with E(6*10mm) connecting bolt.

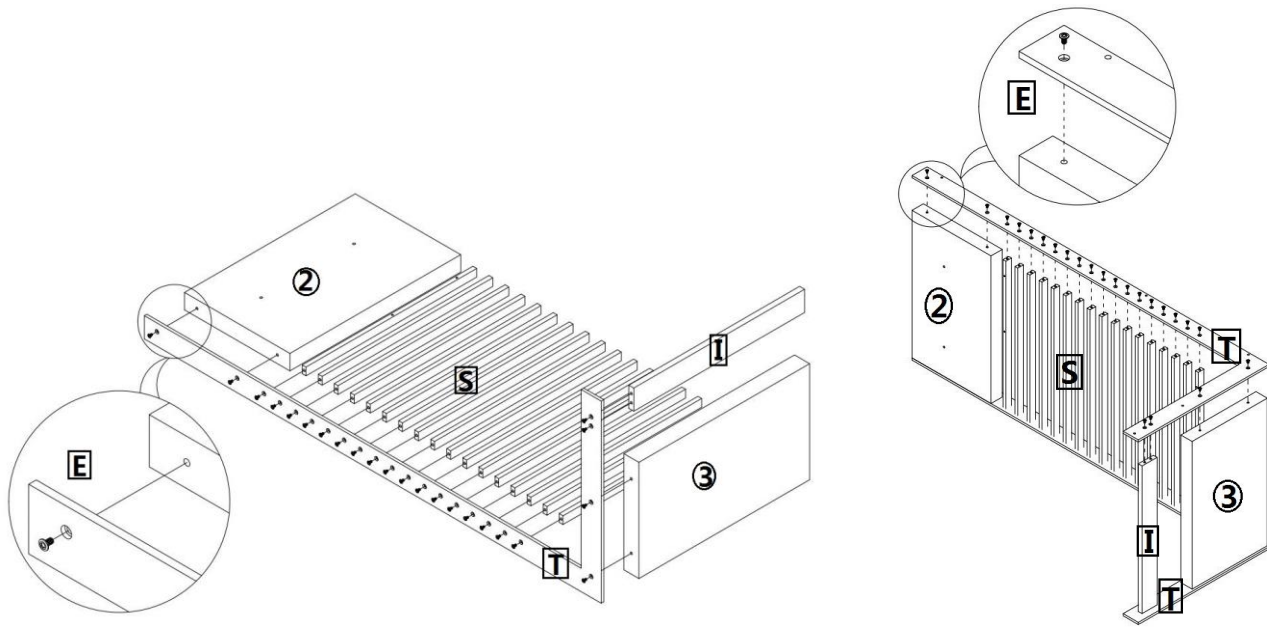

(2) Assemble the front Panel No.9 with the stainless steel tube S with R (6*25mm) connecting bolt.

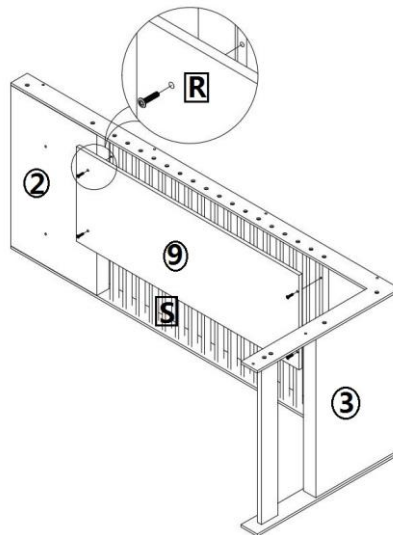

(3) Connect Panel No.2 with Panel No.14 with P (6*30mm) connecting bolt to connect the side return..

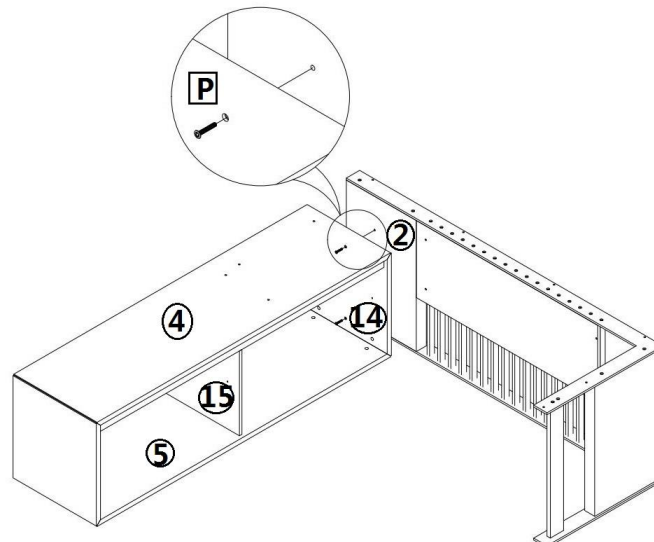

Step 2: Assemble the Table Top Panel, Shelf Panels and Door Panels

- (1) Open 6-1 and 6-4 cartons. Insert screws F (6*150) to pre-built holes around the cable grommet.
Using assistance, turn panel No.1 over and slide the F bolts holes of panel No.11 and No.12 panel.
Use screws J (6*20mm) through the underside of part T stainless steel tube to attach to the top panel No.1.
Using the H gasket & G screw nut, tighten F straight bolts (6*150mm) from the underside of the top panel No.4.

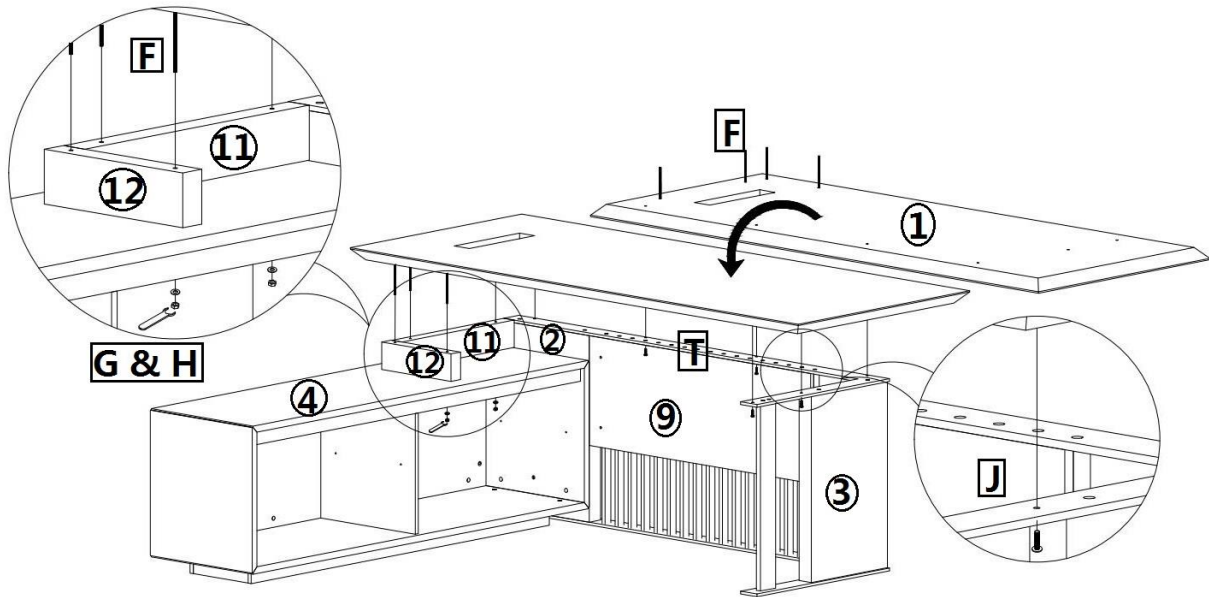

- (2) Insert the support pins No.O into holes located on panel 14 and 15. Insert and rest the shelf panels 13 onto the pins.

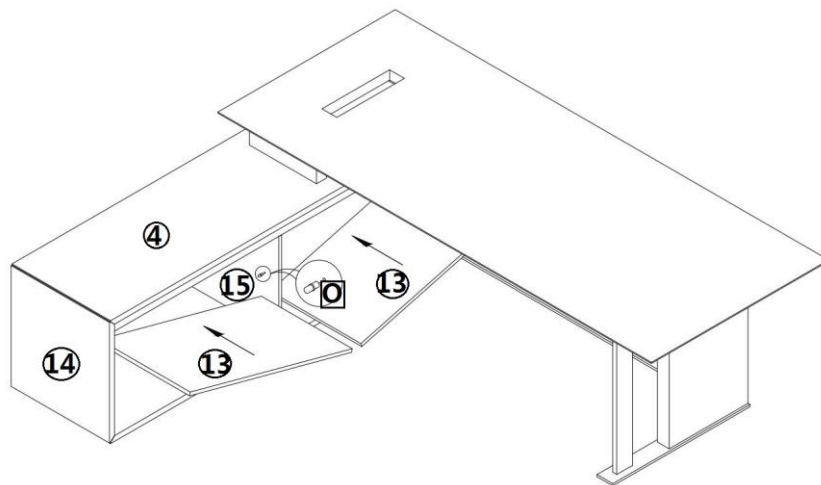

- (3) Assemble cabinet hinges C and D using screws L. Ensure to use the correct hinge for the correct panel.
Base on following instruction, different door assemble different hinge with screw L.

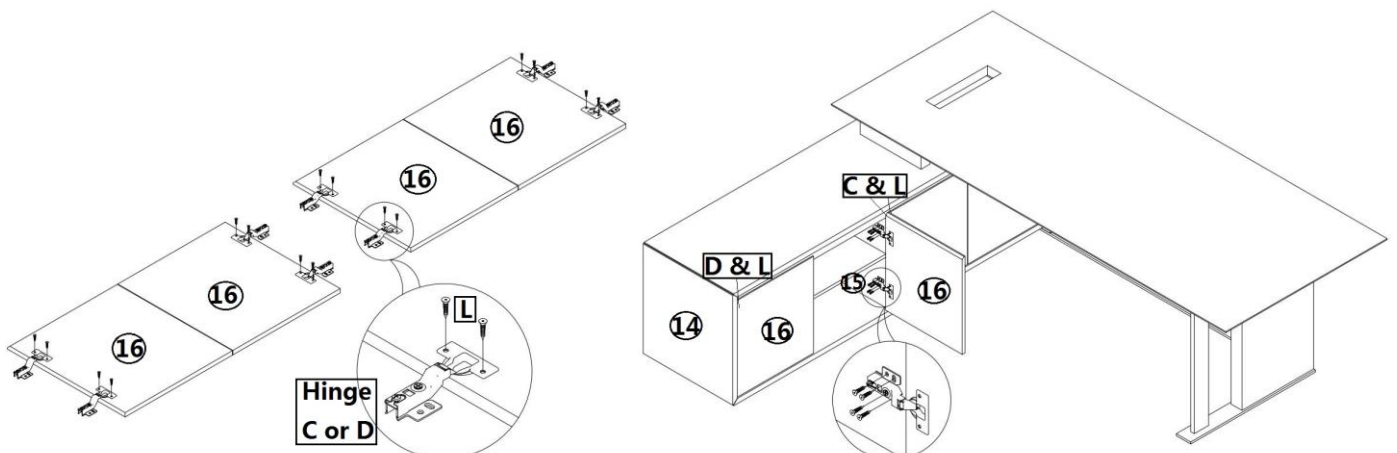

You may choose to use the decals to cover any Cam locks that are visible.

Finished assembly

Do not drag the furniture as this may cause damage to the legs. Instead, ask at least 2 persons to lift carefully with caution from either end.

IMPORTANT: CARE GUIDE FOR YOUR MELAMINE BOARD FURNITURE

Please read up on important information regarding your furniture.

- Dust frequently with a clean damp, lint-free cloth.
- Avoid using chemicals or solvents when cleaning the furniture.
- Do not place hot objects on any furniture surface.
- Avoid exposing your furniture to strong sunlight.
- Do not expose your furniture to any liquids.
- Do not allow sharp or rough object scratch the surface of furniture.
- When moving furniture, do not drag it across the floor.

QR code for hinges adjustment



QR code for drawer runner adjustment



QR code for locks assembly

