

# ASSEMBLY INSTRUCTION

## EXECUTIVE TABLE WITH FIXED SIDE CABINET

### ITEM CODE: M2507-R

This instruction suitable for 180/200\*180\*76cm



#### PRE-ASSEMBLY PREPARATION

Before you start:

1. Choose a clean & spacious assembly area, avoid hard surfaces that may damage the product.
2. Take care when lifting product. It should be assembled as near as possible to the point of use.
3. Ensure that you have all required contents for complete assembly.
4. Always read the assembly instructions carefully before assembly is finished.
5. Keep all hardware parts and packing material out of children.
6. Do not over tighten the screws and bolts as this may cause damage.
7. Estimate assembly time: 2hrs 30 minutes.
8. Additional Tools required is screw-driver.

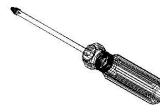

Serious or fatal injuries may occur from furniture toppling over.

For security, please follow the below recommendations:

- Never allow children to climb on or hang off of any part of this product
- Unless specifically designed to accommodate, do not set TVs or other heavy objects on top of this product

If this product has drawers:

- Place the heaviest items in lowest drawers
- Do not open more than 1 drawer at a time as this may cause the product to become unbalanced
- Do not tamper with or remove any drawer interlocking/sliding system
- Please use this product with caution
- This is a permanent label. Do not attempt to remove!

# PRODUCT CHECK

Upon receiving the furniture, please check product size, carton quantity, and confirm the direction of the side cabinet's location you want prior to assembly.

The M2507 executive table set should be packaged in 3 cartons. The shipping mark to be show on 3-1,3-2,3-3.

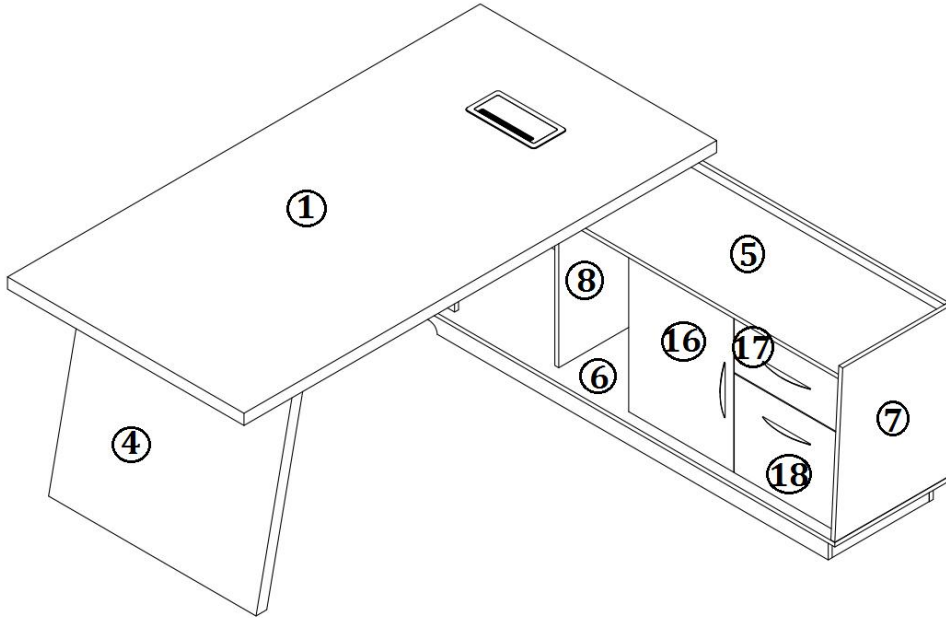

Carton No.	Panel No.	Panel Size (CM)	Qty	Carton No.	Panel No.	Panel Size (CM)	Qty
3-1	1	180*90*5	1	3-3	13	37*8*1.5	3
3-1	2	120*40*1.5	1	3-3	14	56.8*8*1.5	1
3-1	3	116.9*40*1.5	1	3-3	15	17*8*1.5	2
3-2	4	73*79*4	1	3-3	16	51*40*1.5	1
3-3	5	176.8*40.2*1.5	1	3-3	17	40*18*1.5	1
3-3	6	180*45*1.5	1	3-3	18	40*32.7*1.5	1
3-3	7	56*44.8*1.5	2	3-3	19	35*11.8*1.5	2
3-3	8	51.6*38.2*1.5	3	3-3	20	35*22*1.5	2
3-3	9	176.8*56*1.5	1	3-3	21	34.1*11.8*1.5	1
3-3	10	51.6*30*1.5	1	3-3	22	34.1*22*1.5	1
3-3	11	37.6*38*1.5	1	3-3	23	35.1*34.5*0.4	2
3-3	12	170*8*1.5	2	3-3	24	51.6*12*1.5	1

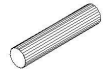
Accessories list ( put in Ctn No.3-3)				
No.	Name	Size(mm)	QTY	Drawing
A	3 in 1 minifix-Bolt	40	86	
	3 in 1 minifix-Cam	∅ 15		
B	Hinge-Full overlay		2	
C	Connecting plate	140*40*2	2	
D	Connecting Bolt		4	
I	Drawer Slide	14 inch	2	
J	Dowel	8*40	4	
K	Shelf support pin	13.5*4.8	8	
M	Handle	128	3	
N	Handle Screw	4*18	6	
O	Grommet	260*127	1	
P	Screw	3.5*14	58	
Q	Screw	3.5*35	8	

## GENERAL ASSMEBLY DETAILS:

### How to use 3 in 1 Mini-Fix Cam & Pins (Accessory A) Fasteners

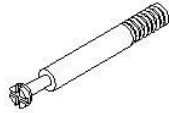

Bolt

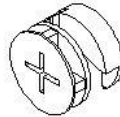

Cam

Cam lock fasteners are used to join two pcs boards together.

1. All white sockets have been pre-installed in the boards to secure the bolts
2. Using a screw driver or cordless drill, do not overtighten Bolts.
3. Use a flathead screwdriver to turn and tighten the Cam lock in a clockwise direction until the head of the pi is tightly secured. **DO NOT USE A CORDLES DRILL**

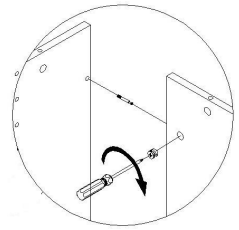

### How to separate drawer sliders?

The drawer slide I1 & I2 may be connected.

Carefully pull out slide part I2 and press the plastic clip/lever to unlock to fully separate the two parts of the runner.

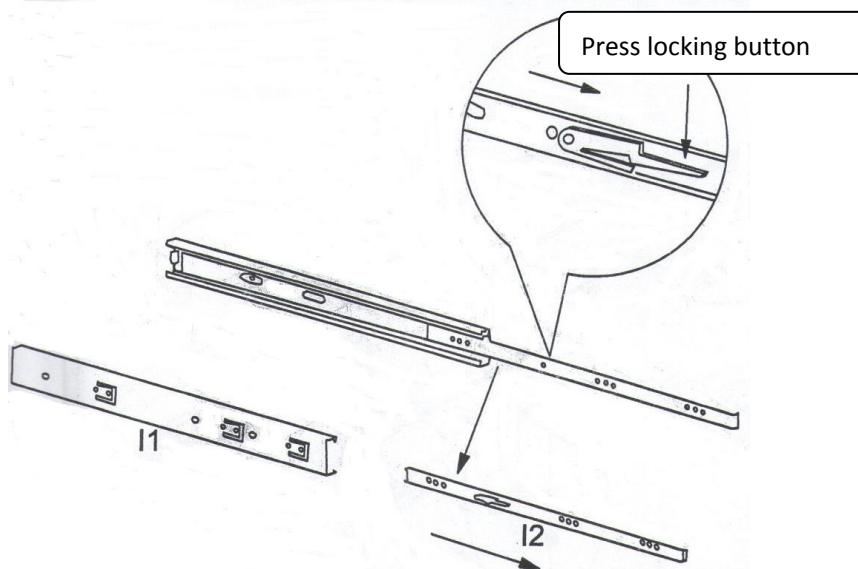

## START TO ASSEMBLE

### Step 1: Assemble side cabinet

1. Take out Panel No.7 & 8 with guiding holes for drawer slider from carton No.3-3.  
As per guiding hole, tighten slide I1 onto panel No.7 & 8 with P Screws (3.5\*14MM).

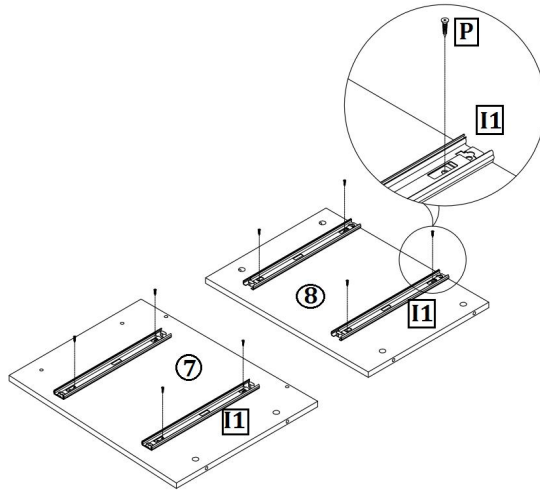

2. Take out Panel No.5 & 9 from carton No.3-3. Connect Panel No.5 & 9 by accessory A.

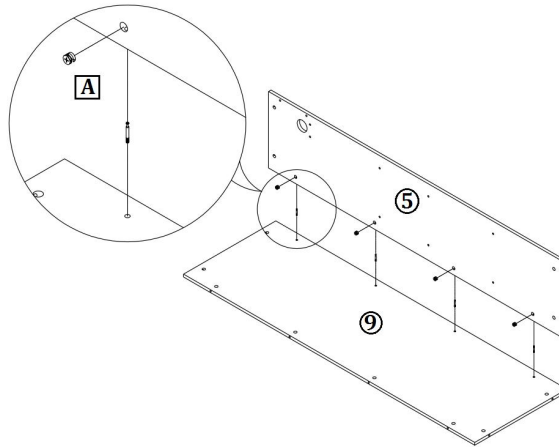

3. Screw A bolts onto top panel No.5. Knock J dowel into holes which connect Panel No.24 & 5.  
Push A-bolt of panel No.5 into holes in panel No.8,10 and then tighten A CAM on panel No.8, 10.

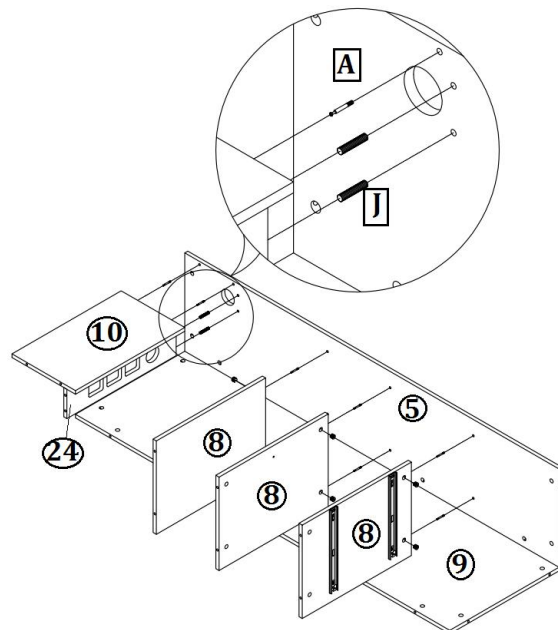

4. Assemble the side panel No. 7 with panel No.5 &9 by accessory A.

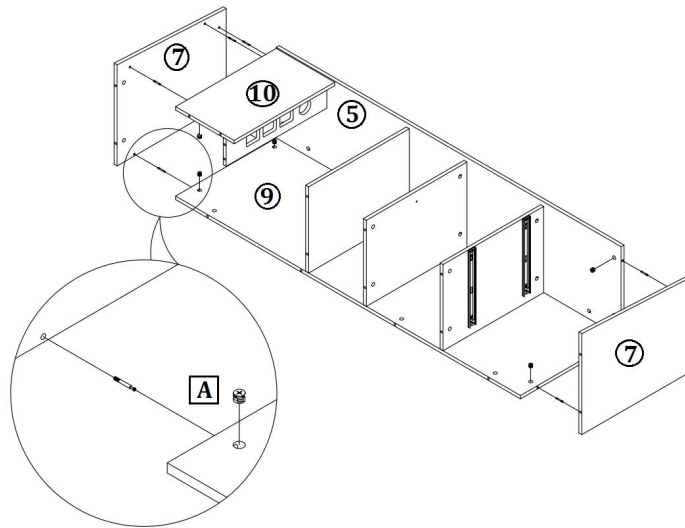

5. Screw A bolts onto bottom panel No.6. Knock J dowel into holes which connect Panel No.24 & 6. Push A-bolt of panel No.6 into holes in panel No.7,8,9,10 and then tighten A CAM.

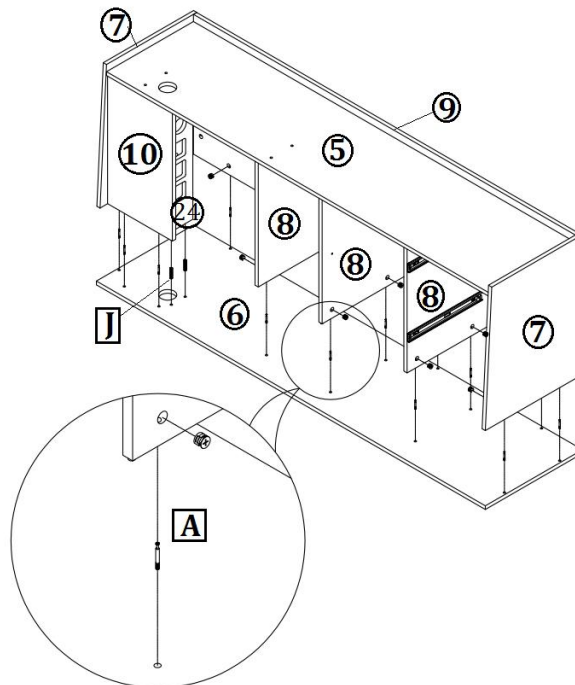

6. Assemble the bottom base of the side cabinet. Fix Panel No. 12 & 13 by accessory A as below.

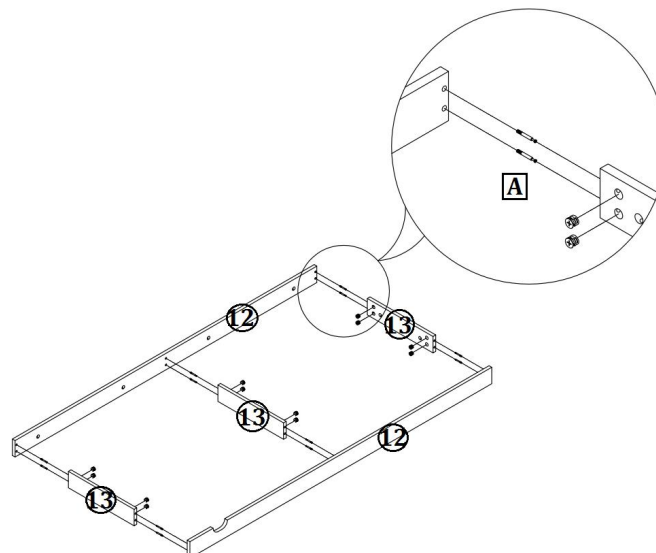

7. Assemble the bottom base finished in the previous step with the bottom panel No.6 by accessory A.

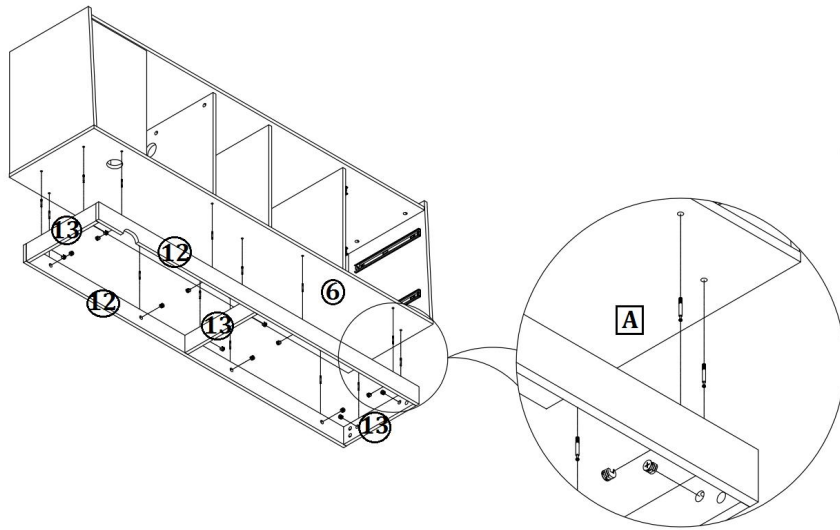

8. Assemble the support frame to connect the main table top on the side cabinet. Fix Panel No. 14 & 15 by accessory A as below.

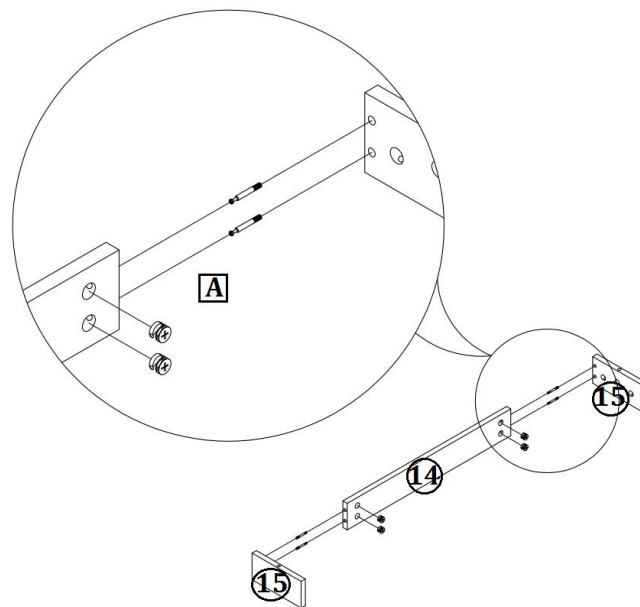

9. Assemble the support frame finished in the previous step with the top panel No.5 by accessory A.

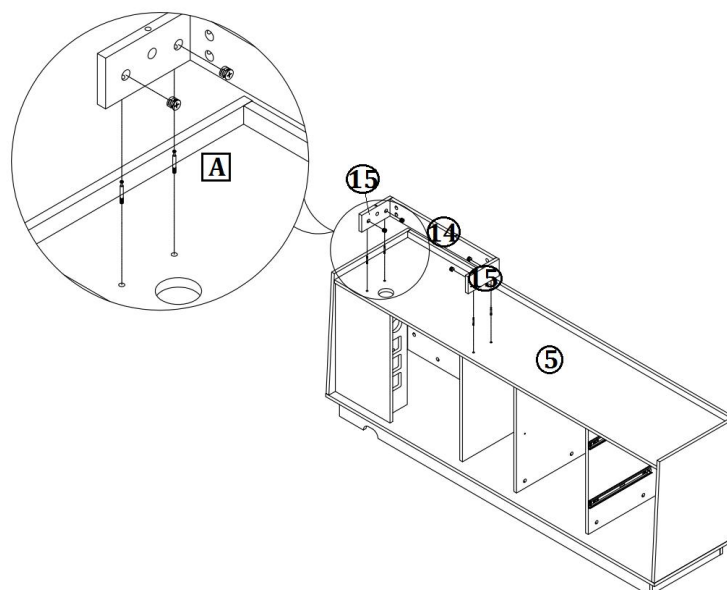

## Step 2: Assemble drawer and door panel

1. Pick up door panel No.16 and fix on Hinge B by screw P.

Assemble door panel No.16 on side cabinet with P screw (3.5\*14mm).

Tighten screw N with handle M.

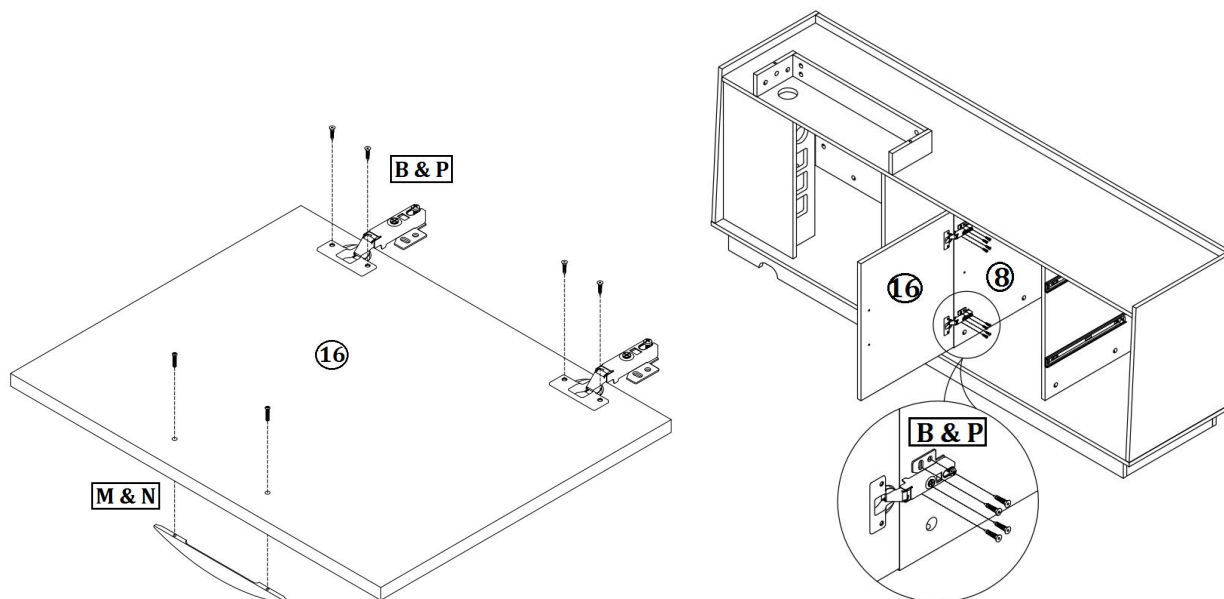

2. Knock accessory K into panel No.8 with guiding holes. Put shelf panel No.11 above the shelf support pin K.

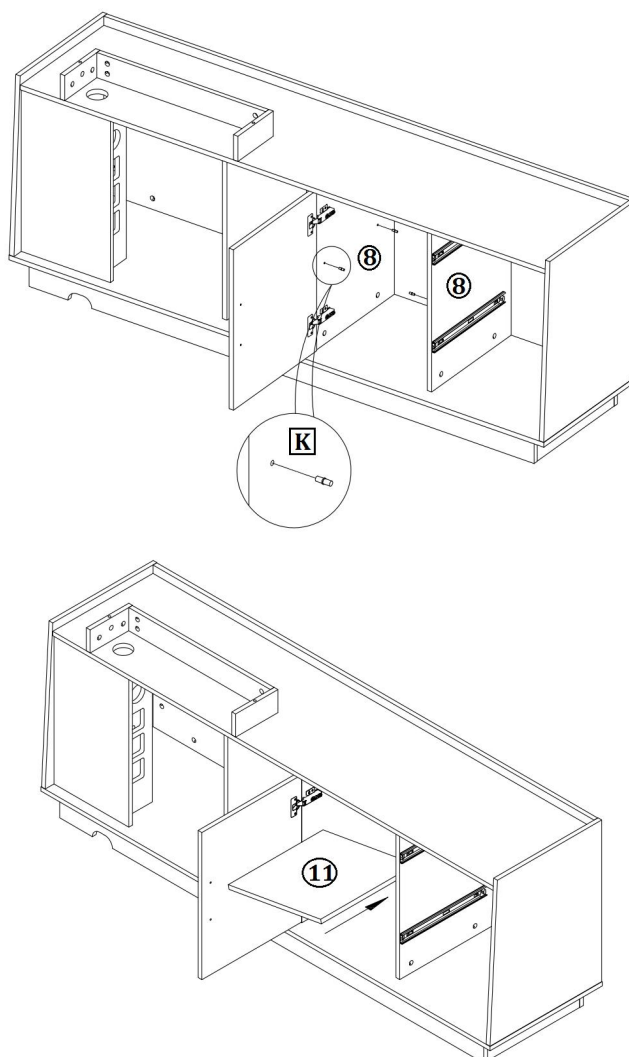

3. Take out panel No.17,18,19,20,21,22,23 from Carton 3-3. Assemble them as following drawing.

Tighten drawer slide I2 with P screws (3.5\*14mm) on outside of panel No.19 & 20.

Assemble the handle M on panel No. 17, 18 by screw N.

Assemble panel No.17 & 19, 18 & 20 with A bolt and CAM. And then Insert panel No.23.

Tighten Q screws (3.5\*35mm) by panel No.19 & 21, 20 & 22.

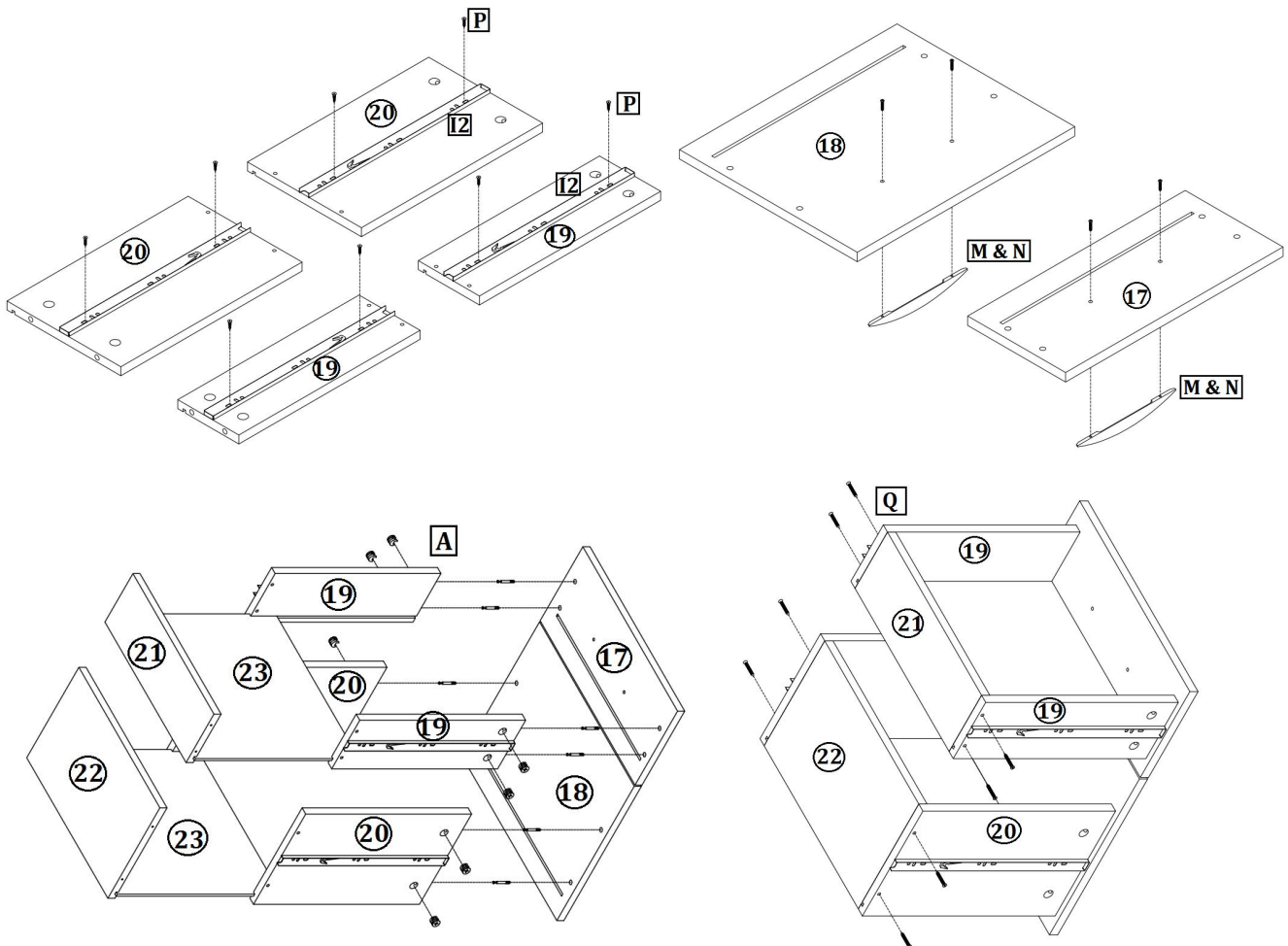

4. Push I2 slide on the drawer into I1 slide on side cabinet.

If drawers cannot move smoothly or fully close, press locking button on slide I2, fully separate, and insert the slide again.

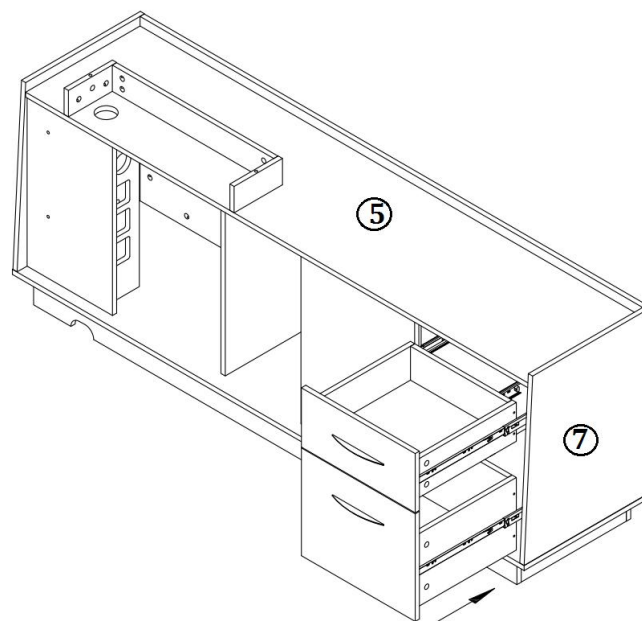

**Step 3: Assemble main table**

1. Take out leg panel No.2 from Carton No. 3-1, panel No.4 from Carton No. 3-2. Connect them by accessory A. Assemble plate C onto panel No 4.

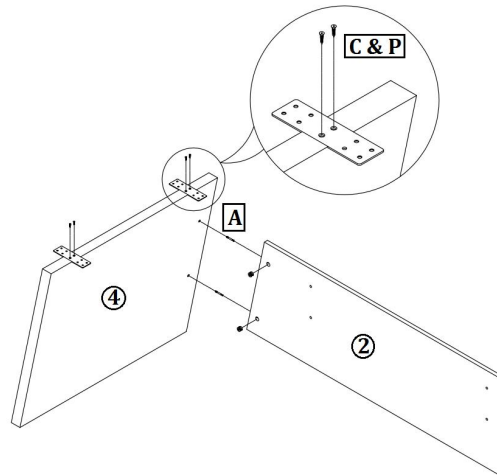

2. Connect panel No.3 and 10 in the side cabinet by accessory A as following drawing.

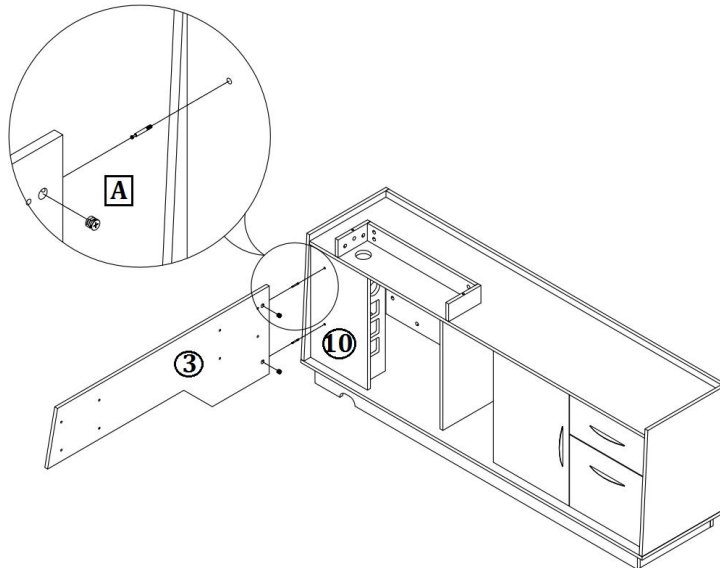

3. Connect panel No.2, 3 by accessory D. Below are 2 dimension options: 2.0m or 1.8m, pls choose what you want.

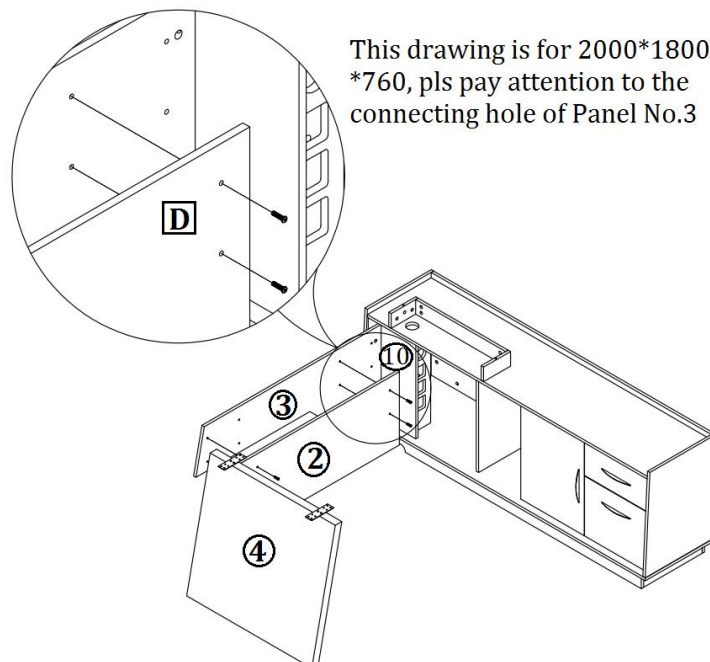

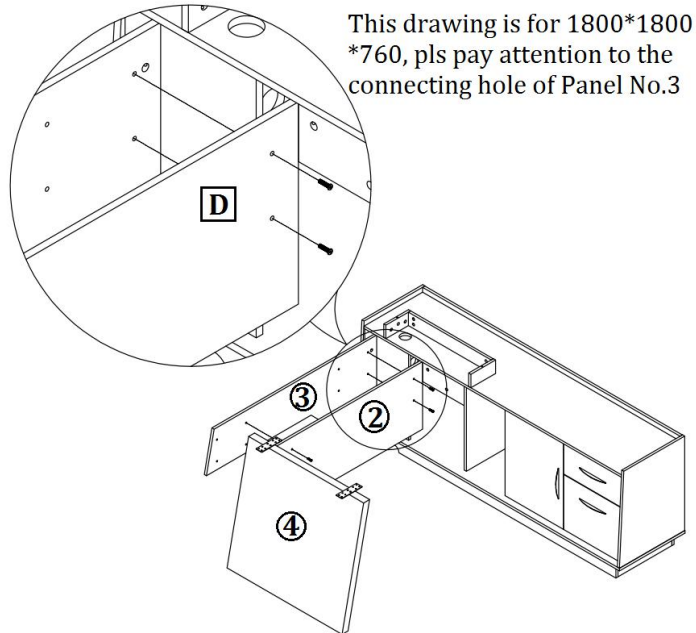

This drawing is for 1800\*1800\*760, pls pay attention to the connecting hole of Panel No.3

**4. Assemble the main table by connecting Panel No.1 & 4 with screw P, panel No.1 & 15 with accessory A as below drawing. Below are 2 dimension options: 2.0m or 1.8m, pls choose the connecting hole of table top you want.**

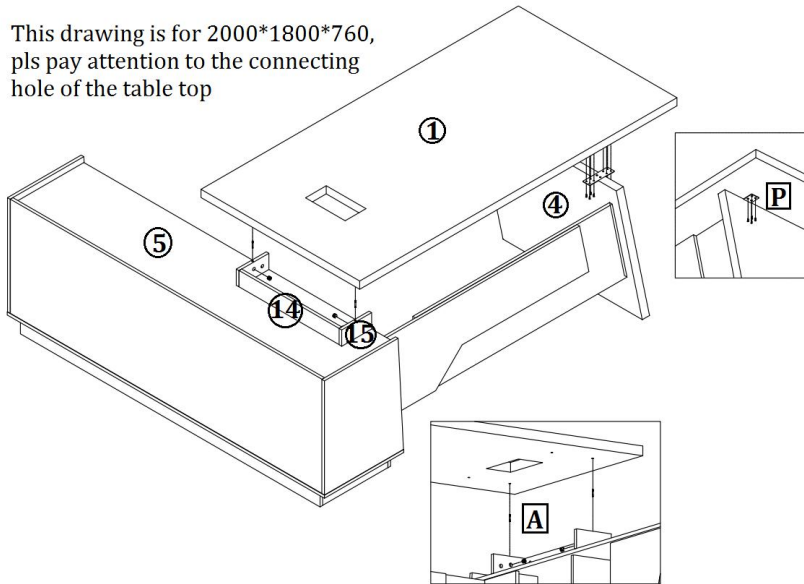

This drawing is for 2000\*1800\*760, pls pay attention to the connecting hole of the table top

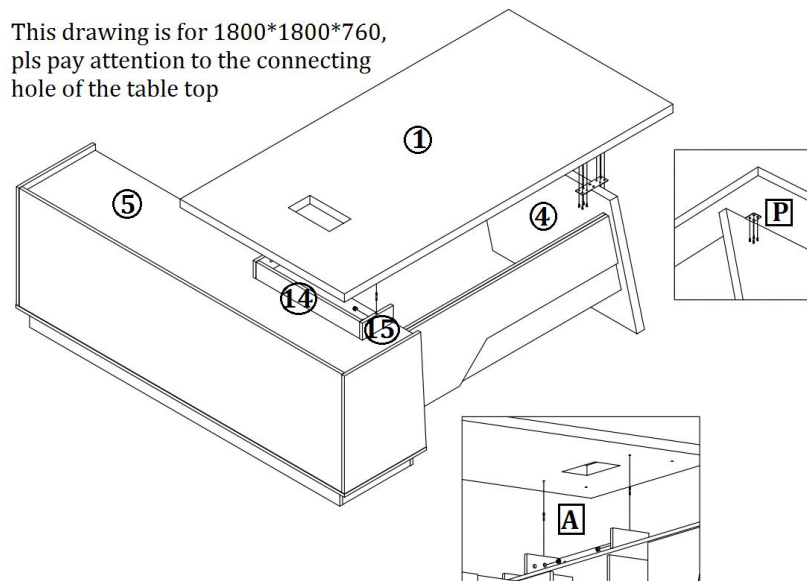

This drawing is for 1800\*1800\*760, pls pay attention to the connecting hole of the table top

**5. Put the cable Grommet O onto the table top Panel No.1 as below.**

**(Note: Left one is 2000\*1800\*760; Right one is 1800\*1800\*760)**

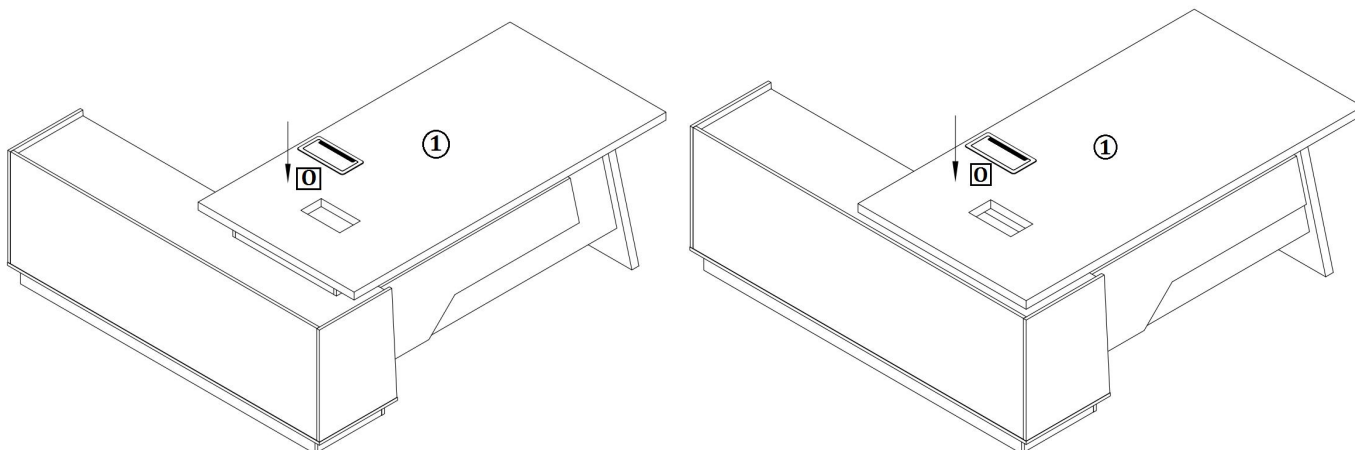

**Attention: Stick screw cover sticker on visible A Cam as per request.**

**Finished assembly**

## **FINAL NOTE:**

**Do not drag the furniture as this may cause damage to the legs. Instead, ask at least 2 persons to lift carefully with caution from either end.**

### **IMPORTANT: CARE GUIDE FOR YOUR MELAMINE BOARD FURNITURE**

**Please read up on important information regarding your furniture.**

- **Dust frequently with a clean damp, lint-free cloth.**
- **Avoid using chemicals or solvents when cleaning the furniture.**
- **Do not place hot objects on any furniture surface.**
- **Avoid exposing your furniture to strong sunlight.**
- **Do not expose your furniture to any liquids.**
- **Do not allow sharp or rough object scratch the surface of furniture.**
- **When moving furniture, do not drag it across the floor.**