

Parts List

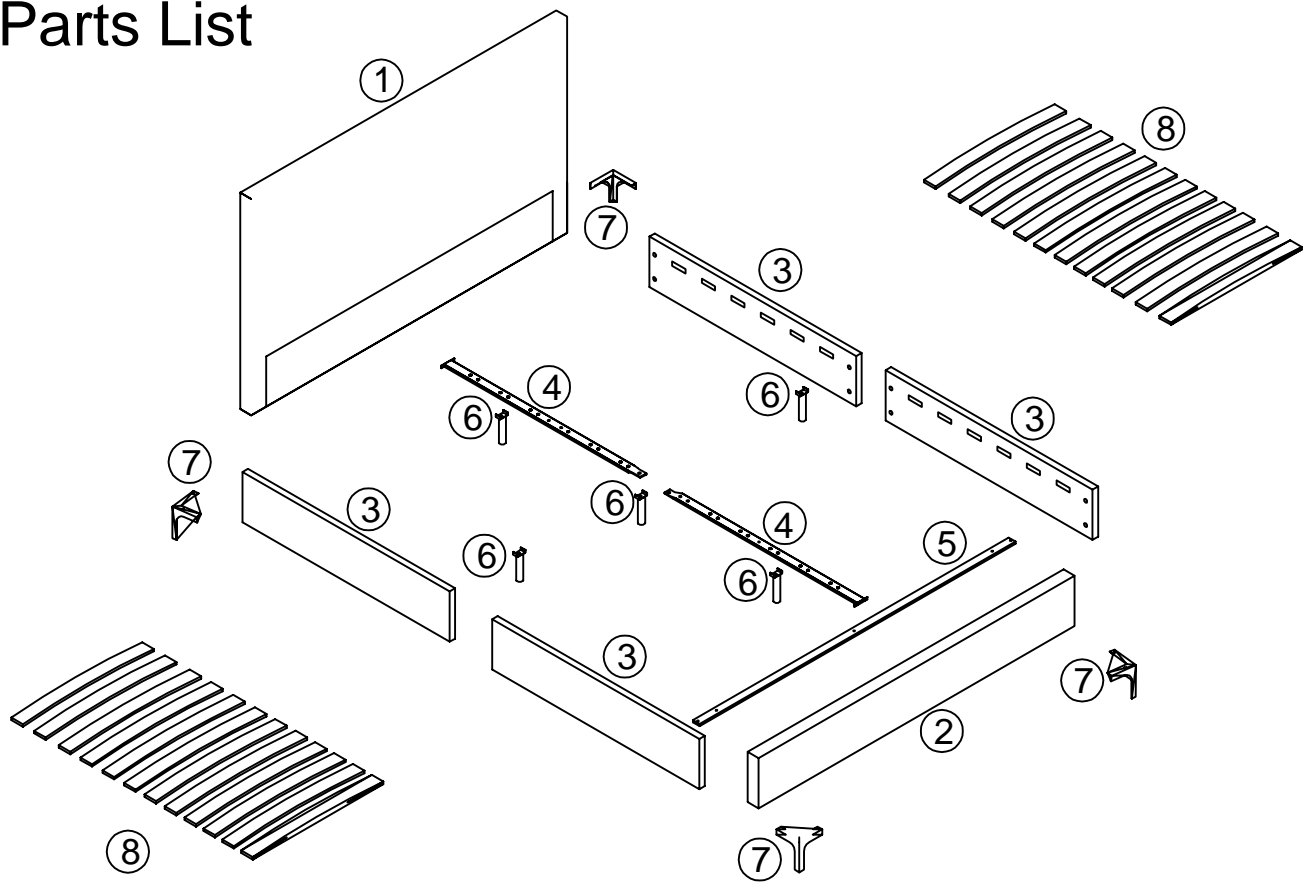

Hardware List







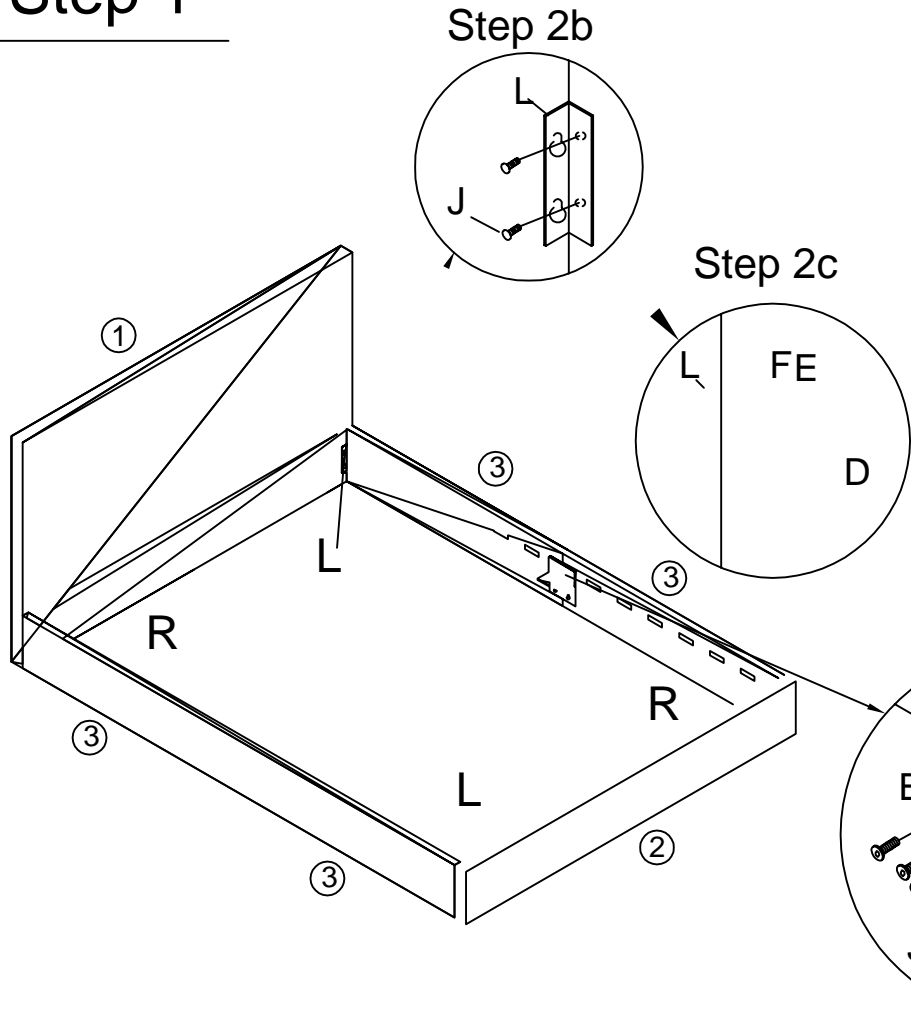

Label	Picture	Description	Qty	Label	Picture	Description	Qty
A		Double Plastic Cap	12	H		Hex M8x35	1
B		L Bracket Plate	2	I		Bolt	6
C		Connection	2	J		Bolt M6x20	20
D		Bolt M8x25	8	K		Screw 4x25mm	16
E		Spring Washer	8	L		Connection Plate Left	2
F		Washer M8	12	R		Connection Plate Right	2
G		Nut M6	2				

Tool List

Label	Picture	Description	Qty
T-1		Screw driver(not provided)	1
T-2		Allen key M5	1
T-3		Allen key M4	1
T-4		Spanner	1

Step 1



L  2pcs Connection Plate Left	R  2pcs Connection Plate
D  8pcs Bolt M8x25	Right  8pcs Spring Washer
F  12pcs Washer M8	J  16pcs Bolt M6x20
C  2pcs Connection L Bracket Plate	B  2pcs L Bracket Plate

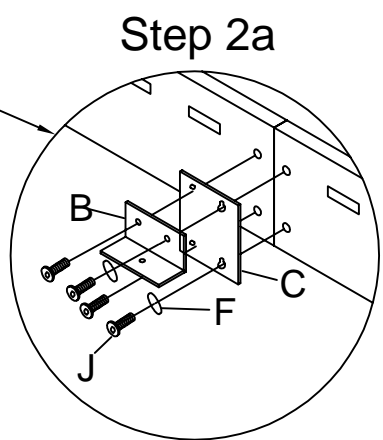



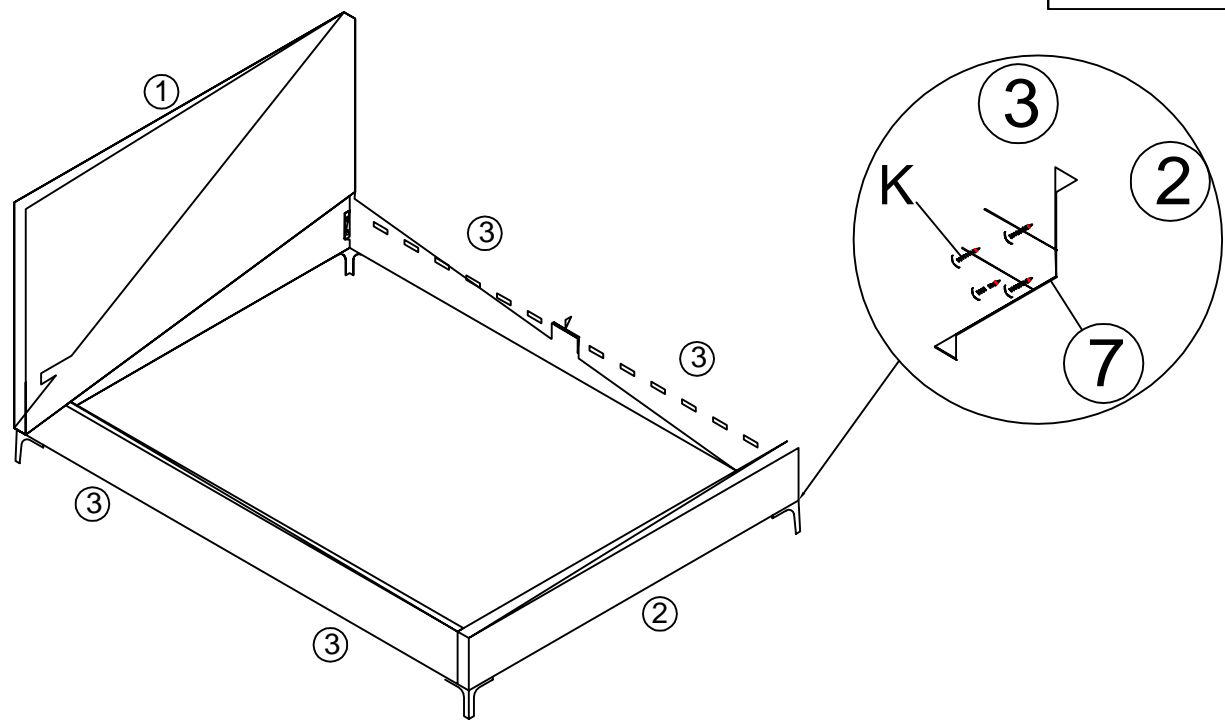

Step 2

K  16pcs Screw 4x25mm



Step 3

H  1pcs Bolt M6x35	G  2pcs Nut M6	I  6pcs Bolt M6x25
		 4pcs Bolt M6x20

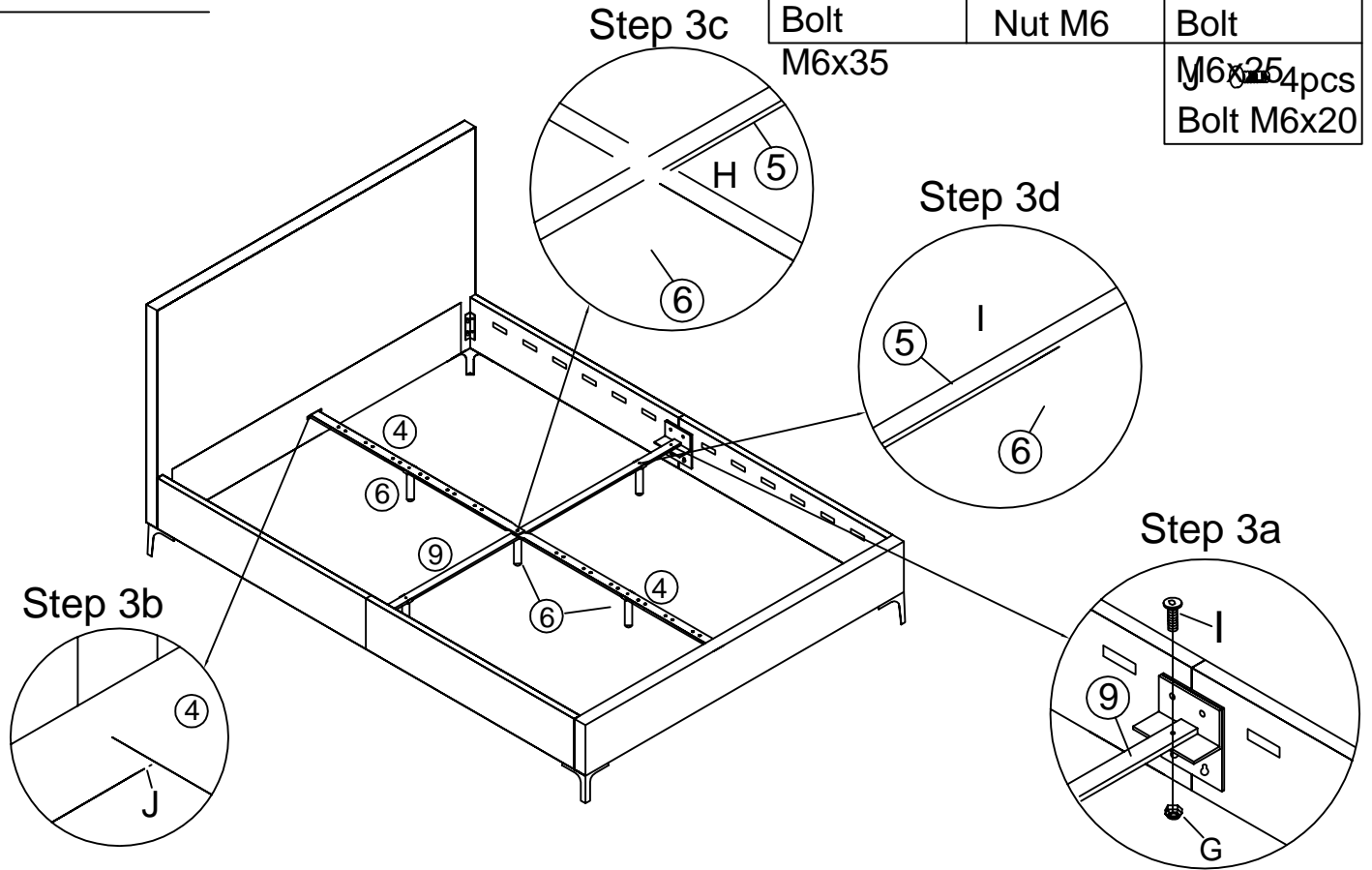

Step 4

A  12pcs Double Plastic Cap

