

ASSEMBLY INSTRUCTIONS

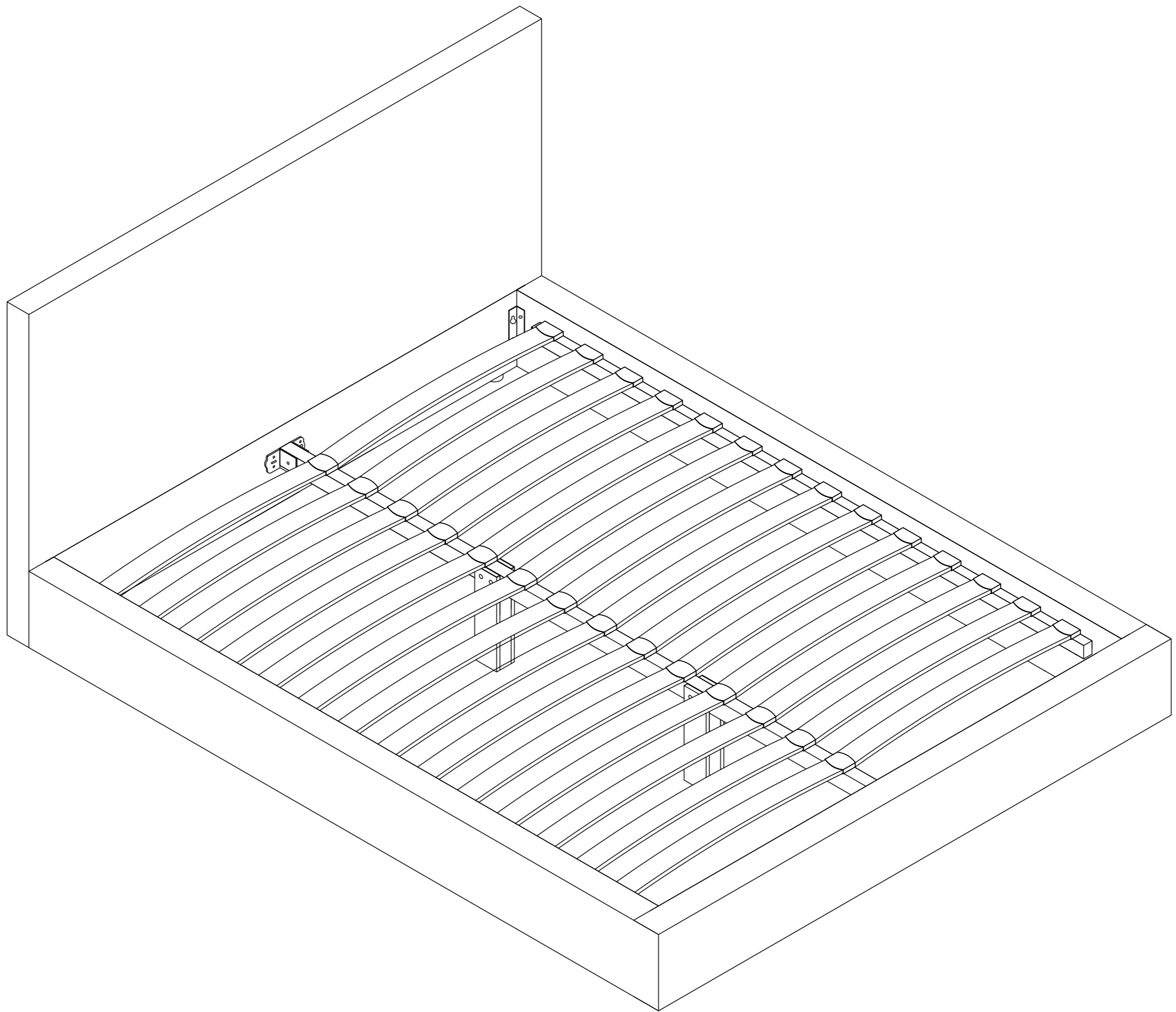

THIS BED IS FOR DOMESTIC USE
AND STRICTLY NOT FOR CONTRACT USE.

Parts list

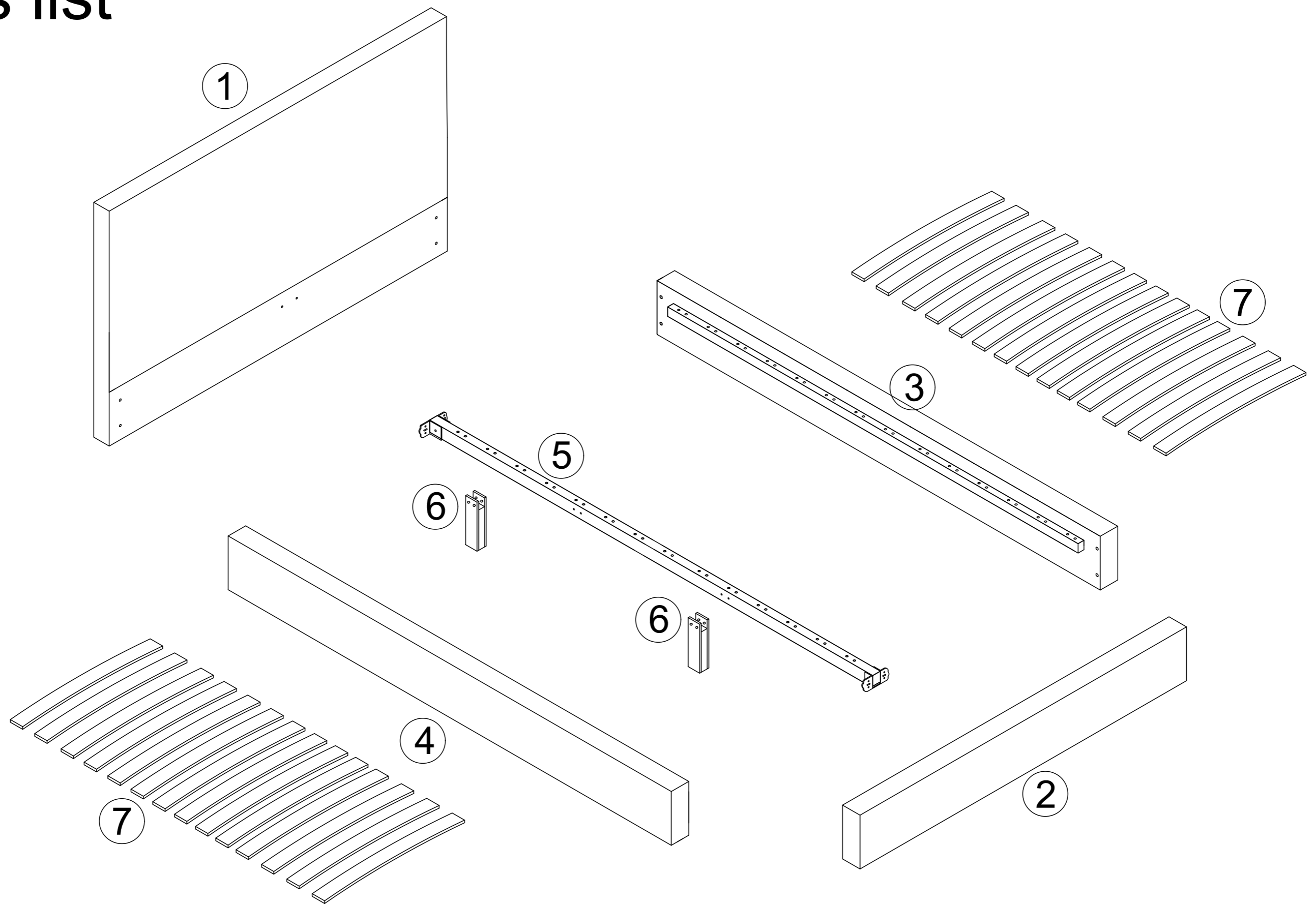

Hardware list

Label	Picture	Description	Qty	Label	Picture	Description	Qty
A		Single Plastic CAP	28	G		Nut	4
B		Double Plastic CAP	14	H		Bolt M8x65mm	4
C		Metal Frame "U"	2	I		Bolt M6x20mm	4
D		Bolt M8x20mm	8	L		Connection Plate Left	2
E		Bolt M8x25mm	8	R		Connection Plate Right	2
F		Screw 3.5x15mm	4				

Tool list

Label	Picture	Description	Qty
T-1		Screw driver(not provided)	1
T-2		Allen key M5	1
T-3		Allen key M4	1
T-4		Spanner	1

Step 1

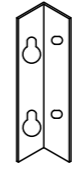
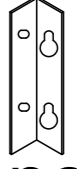
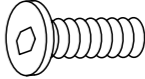
L  2pcs Connection Plate Left	R  2pcs Connection Plate Right
D  8pcs Bolt M8x20mm	

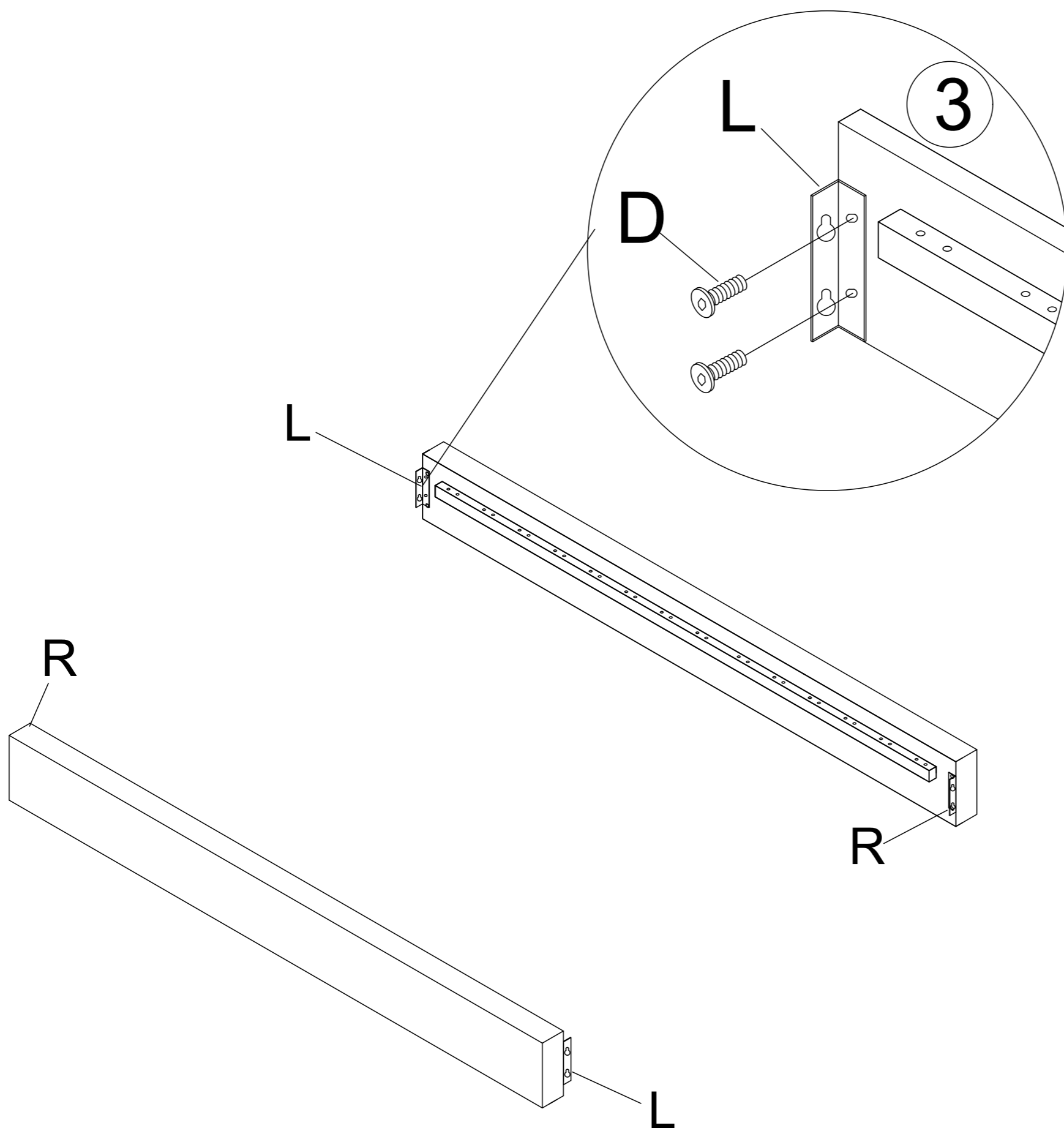

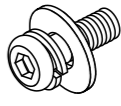

Step 2

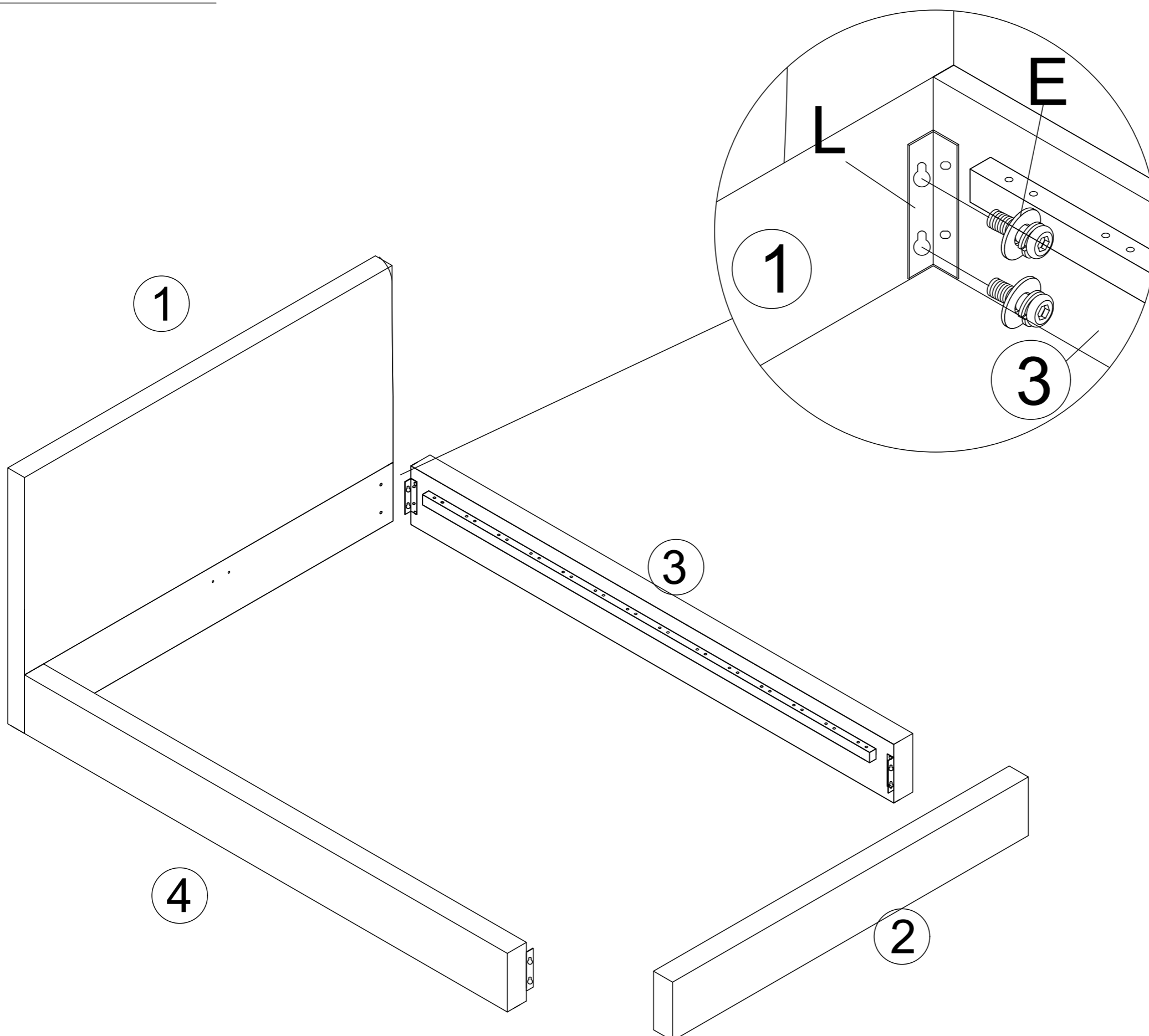
E  8pcs Bolt M8x25mm
--

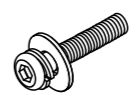
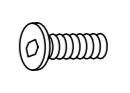

Step 3

Step 3c

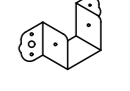
G  4pcs Nut	H  4pcs Bolt M8x65mm	I  4pcs Bolt M6x20mm
F  4pcs Screw 3.5X15mm	C  2pcs Metal Frame "U"	

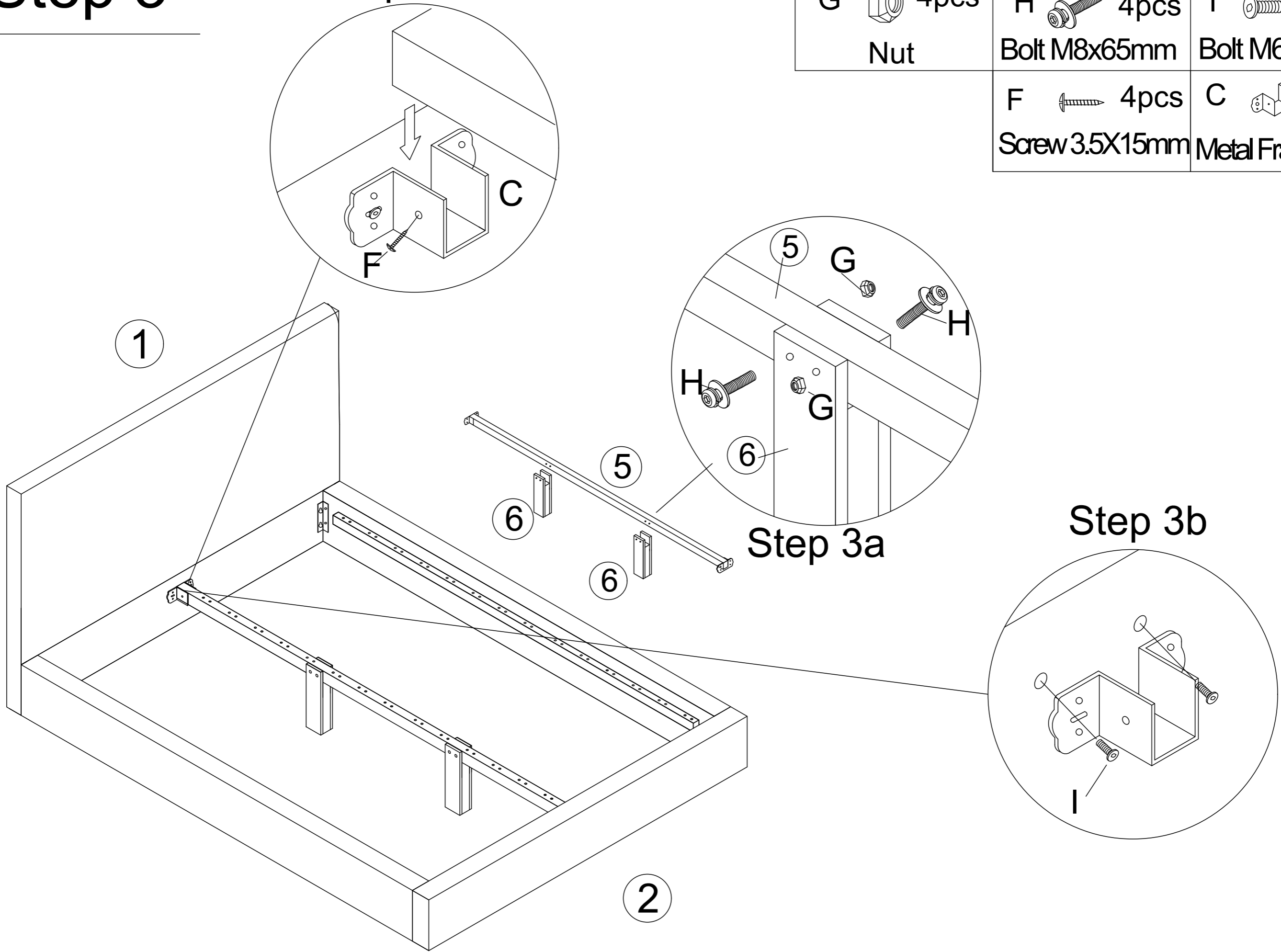

Step 4

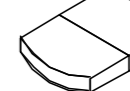
A  28pcs Single Plastic Cap	B  14pcs Double Plastic Cap
---	---

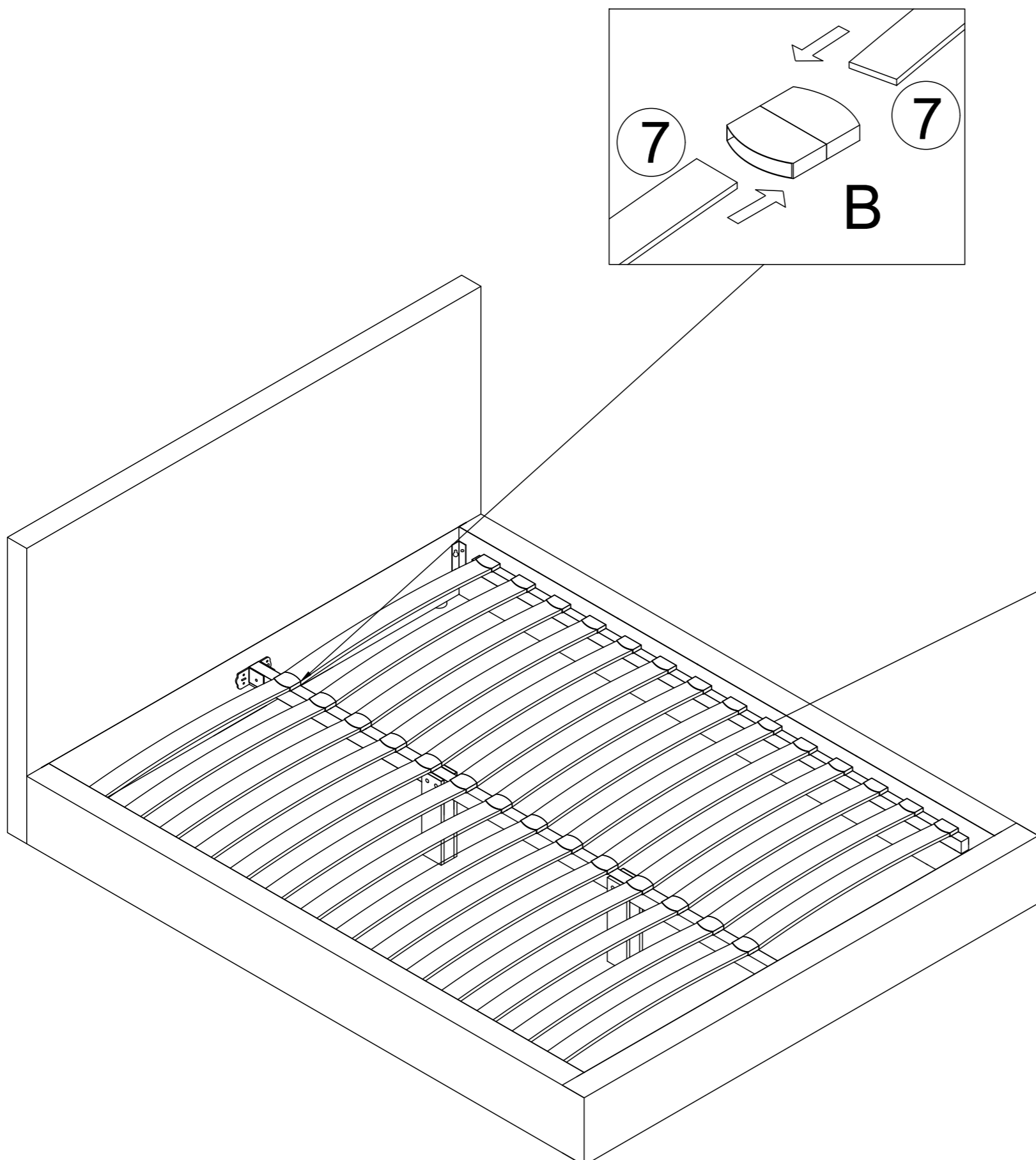

 Make sure all slats
 arched like this when
 assembled