

# ASSEMBLY INSTRUCTIONS

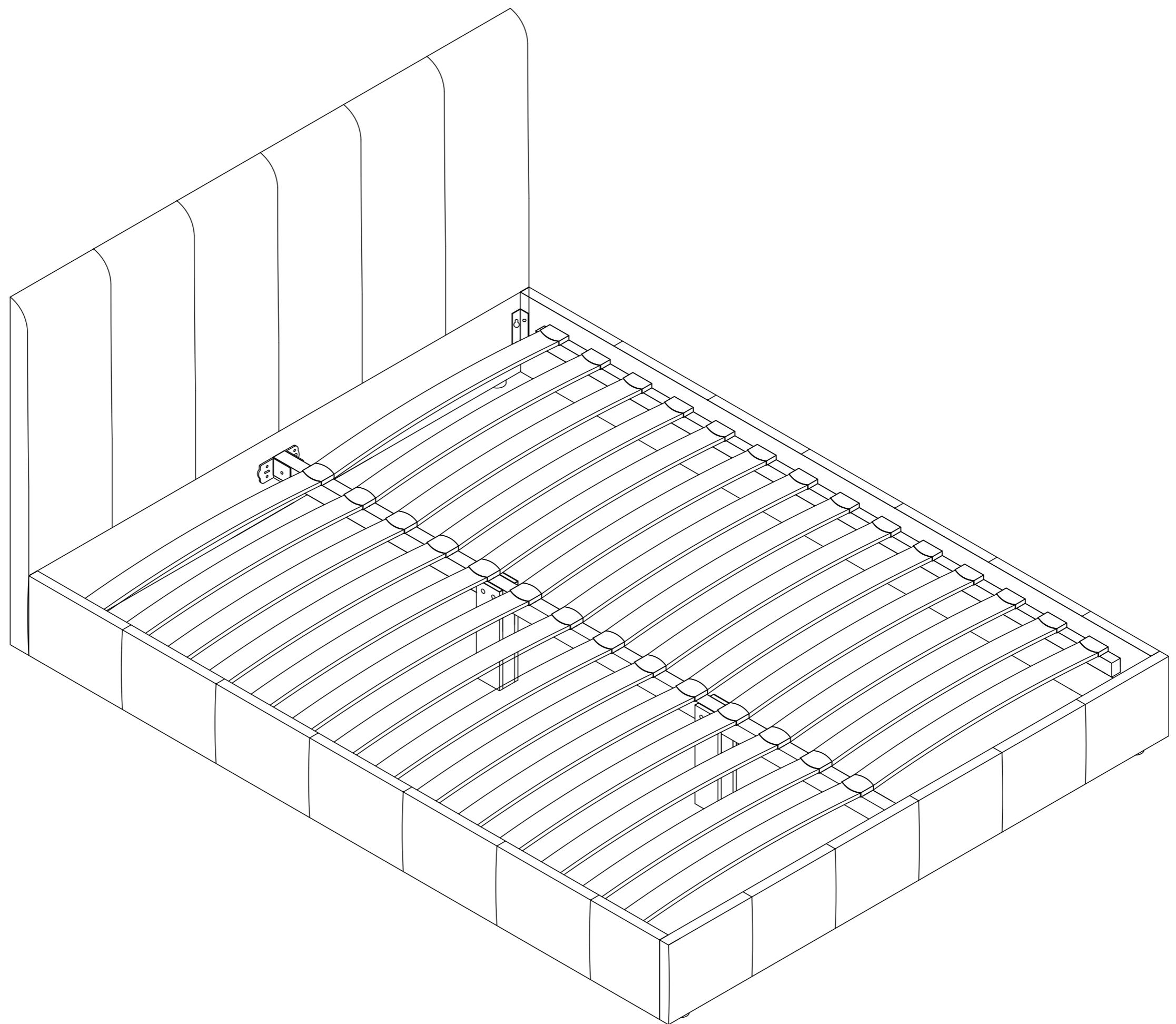

THIS BED IS FOR DOMESTIC USE  
**AND STRICTLY NOT FOR CONTRACT USE.**

# Parts list

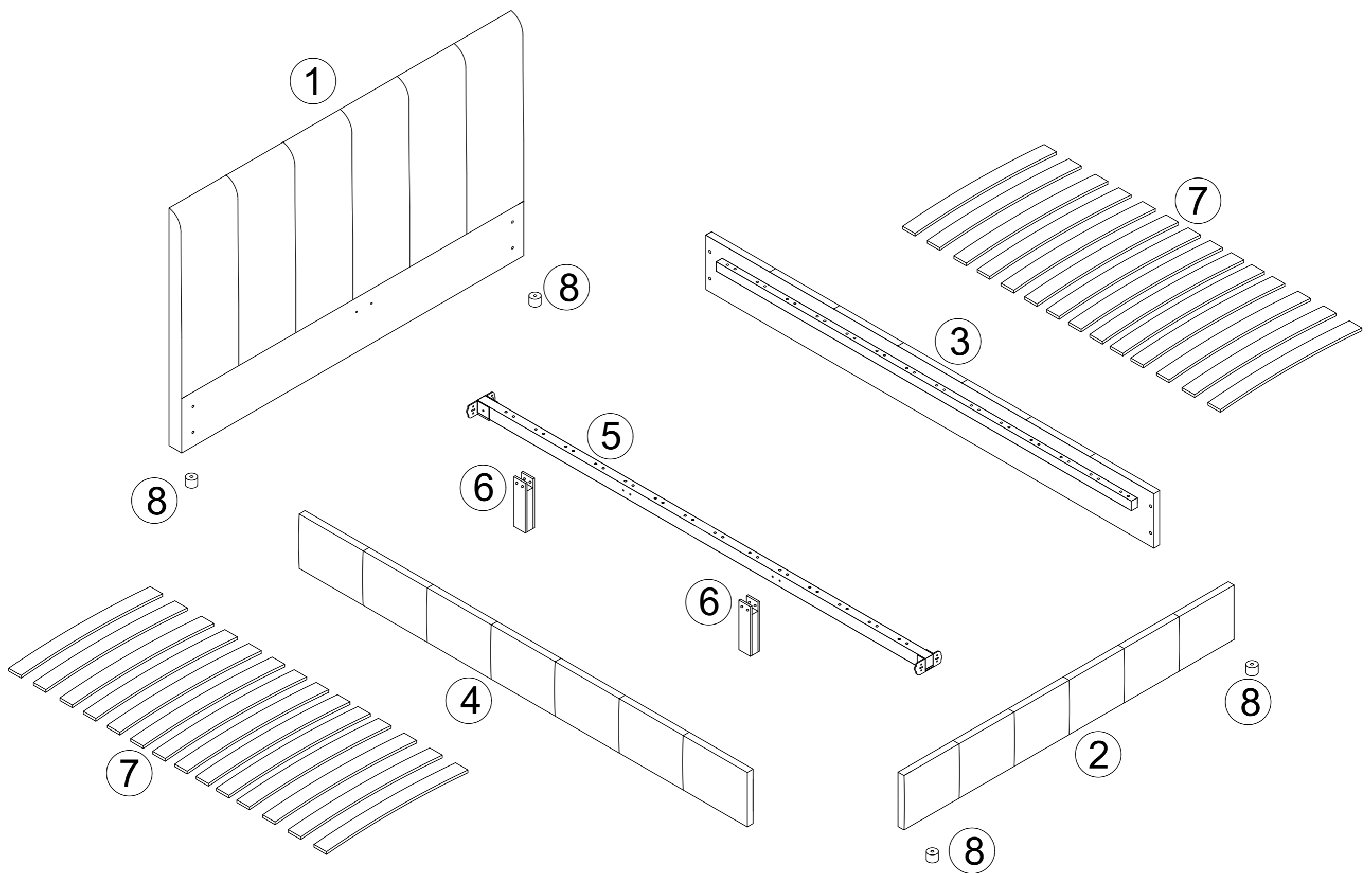

# Hardware list

Label	Picture	Description	Qty	Label	Picture	Description	Qty
A		Single Plastic CAP	28	G		Nut	4
B		Double Plastic CAP	14	H		Bolt M8x65mm	4
C		Metal Frame "U"	2	I		Bolt M6x20mm	4
D		Bolt M8x20mm	8	J		Screw 3.5x15mm	4
E		Bolt M8x25mm	8	L		Connection Plate Left	2
F		Screw 4x45mm	4	R		Connection Plate Right	2

# Tool list

Label	Picture	Description	Qty
T-1		Screw driver(not provided)	1
T-2		Allen key M5	1
T-3		Allen key M4	1
T-4		Spanner	1

# Step 1

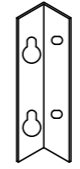
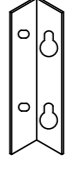
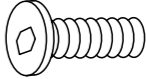
L  2pcs Connection Plate Left	R  2pcs Connection Plate Right
D  8pcs Bolt M8x20mm	

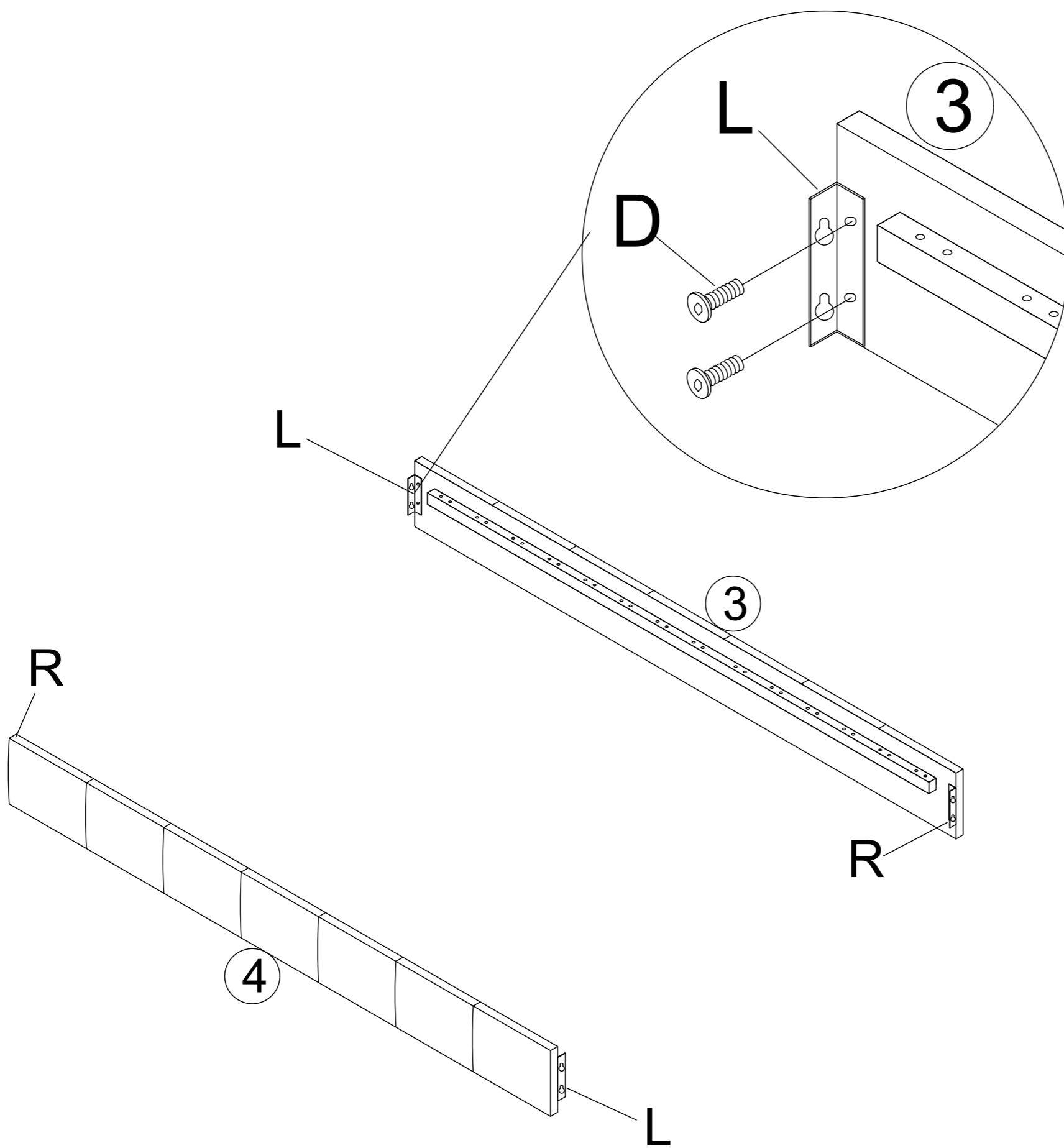

# Step 2

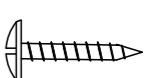
F  4pcs Screw 4x45mm
--

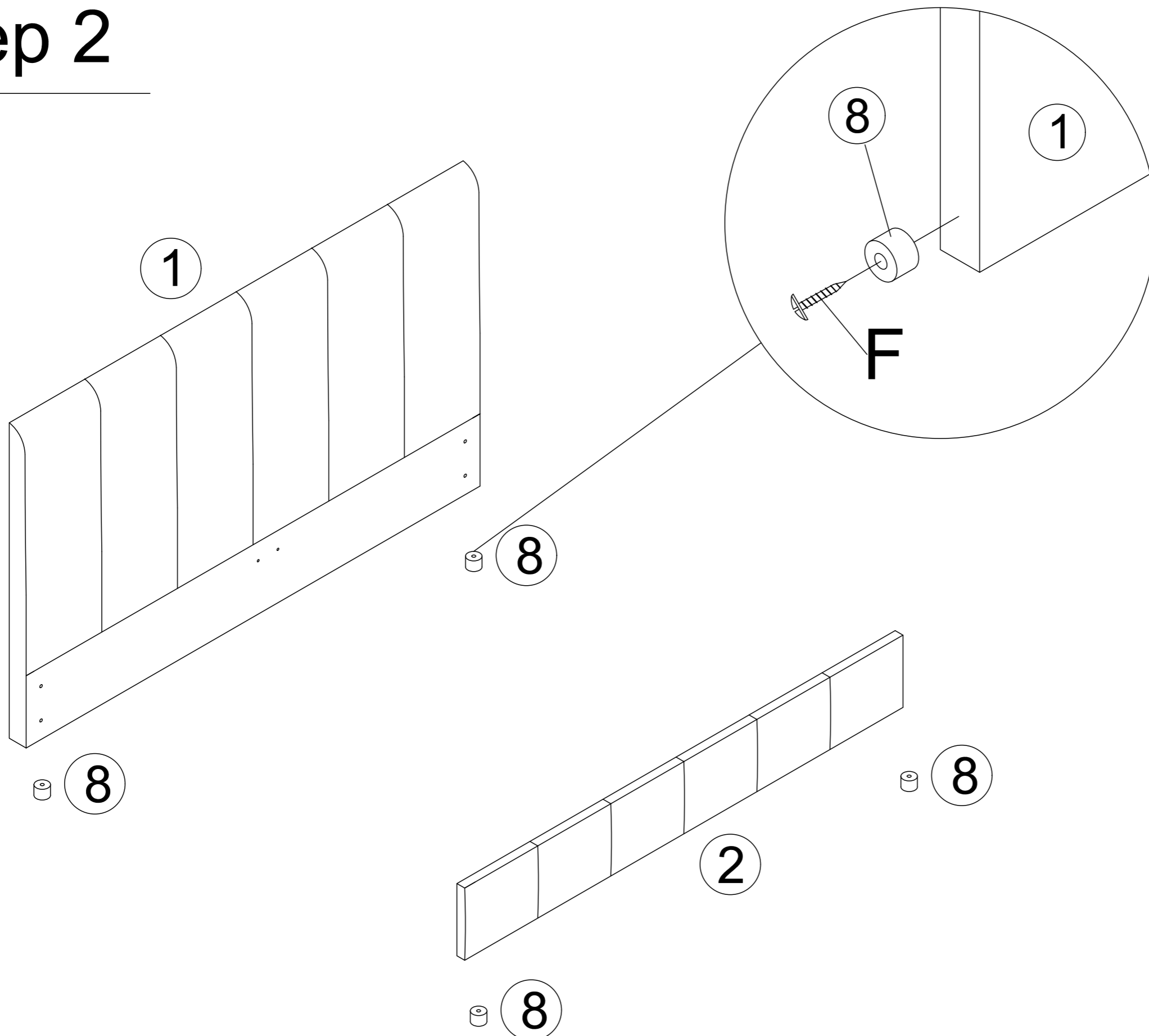

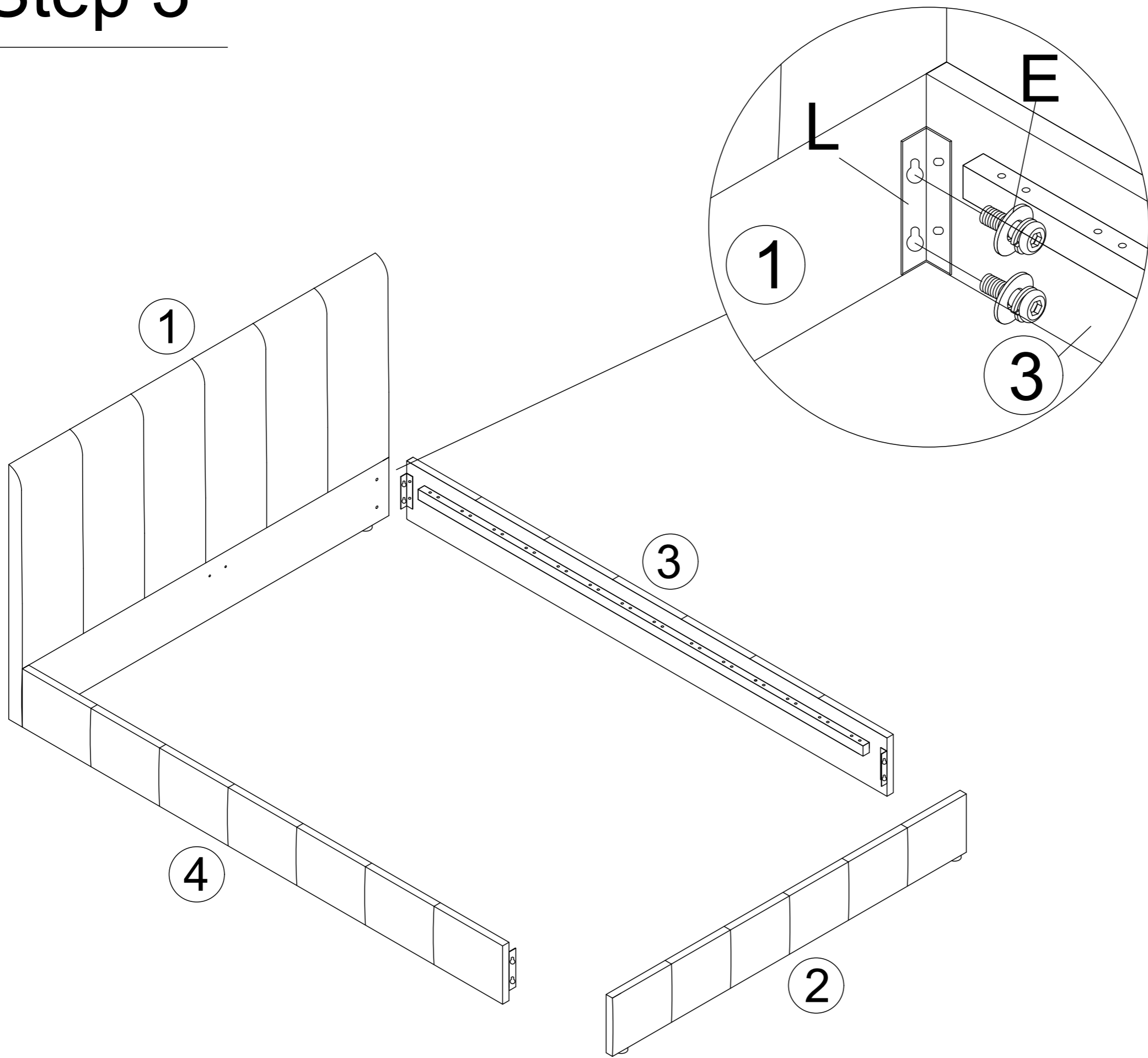

# Step 3

E  8pcs  
Bolt M8x25mm

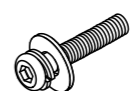

# Step 4

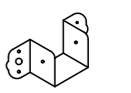
G  4pcs Nut	H  4pcs Bolt M8x65mm	I  4pcs Bolt M6x20mm
J  4pcs Screw 3.5X15mm	C  2pcs Metal Frame "U"	

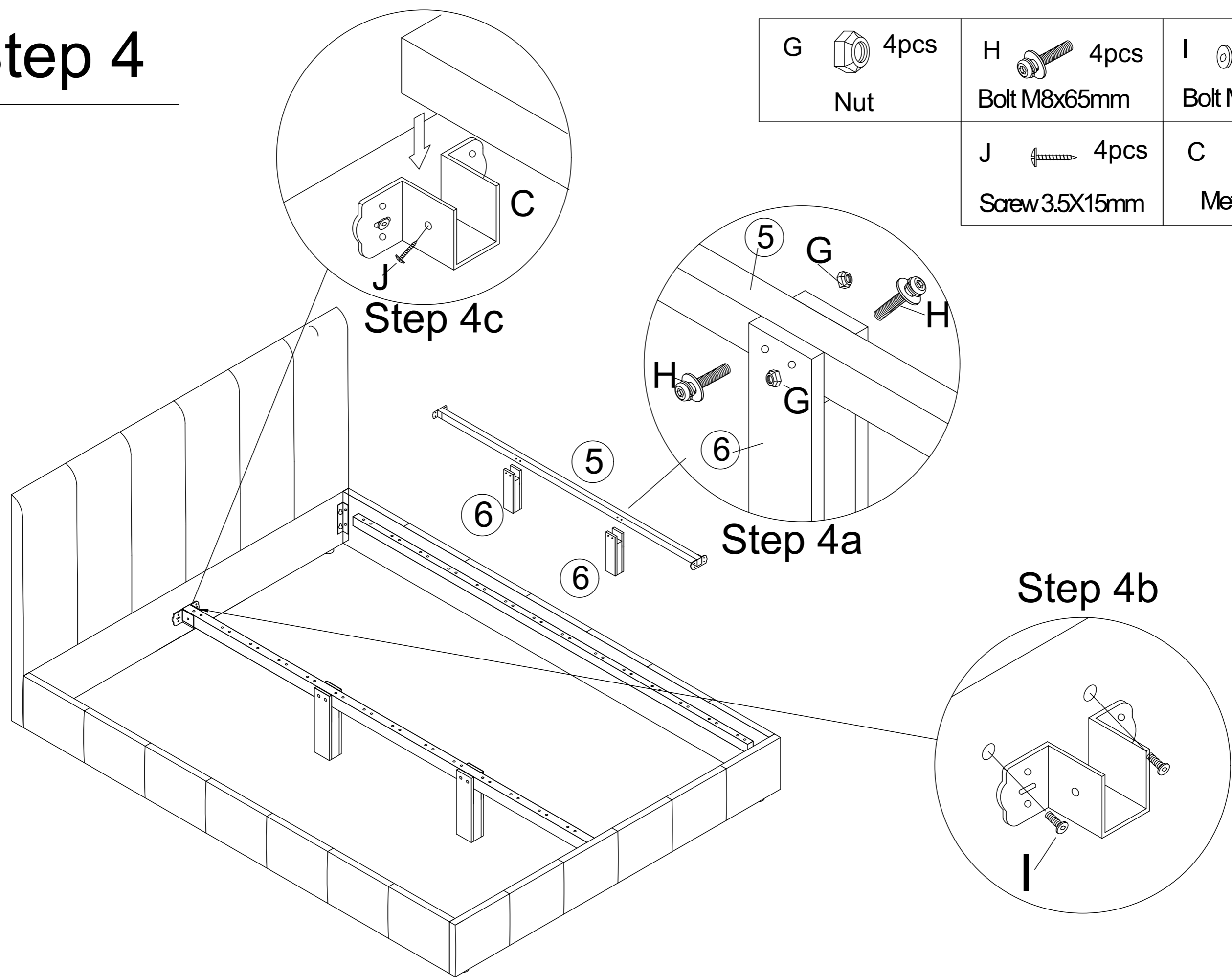

# Step 5

**A**  28pcs  
Single  
Plastic Cap

**B**  14pcs  
Double  
Plastic Cap

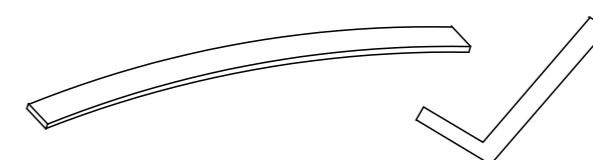
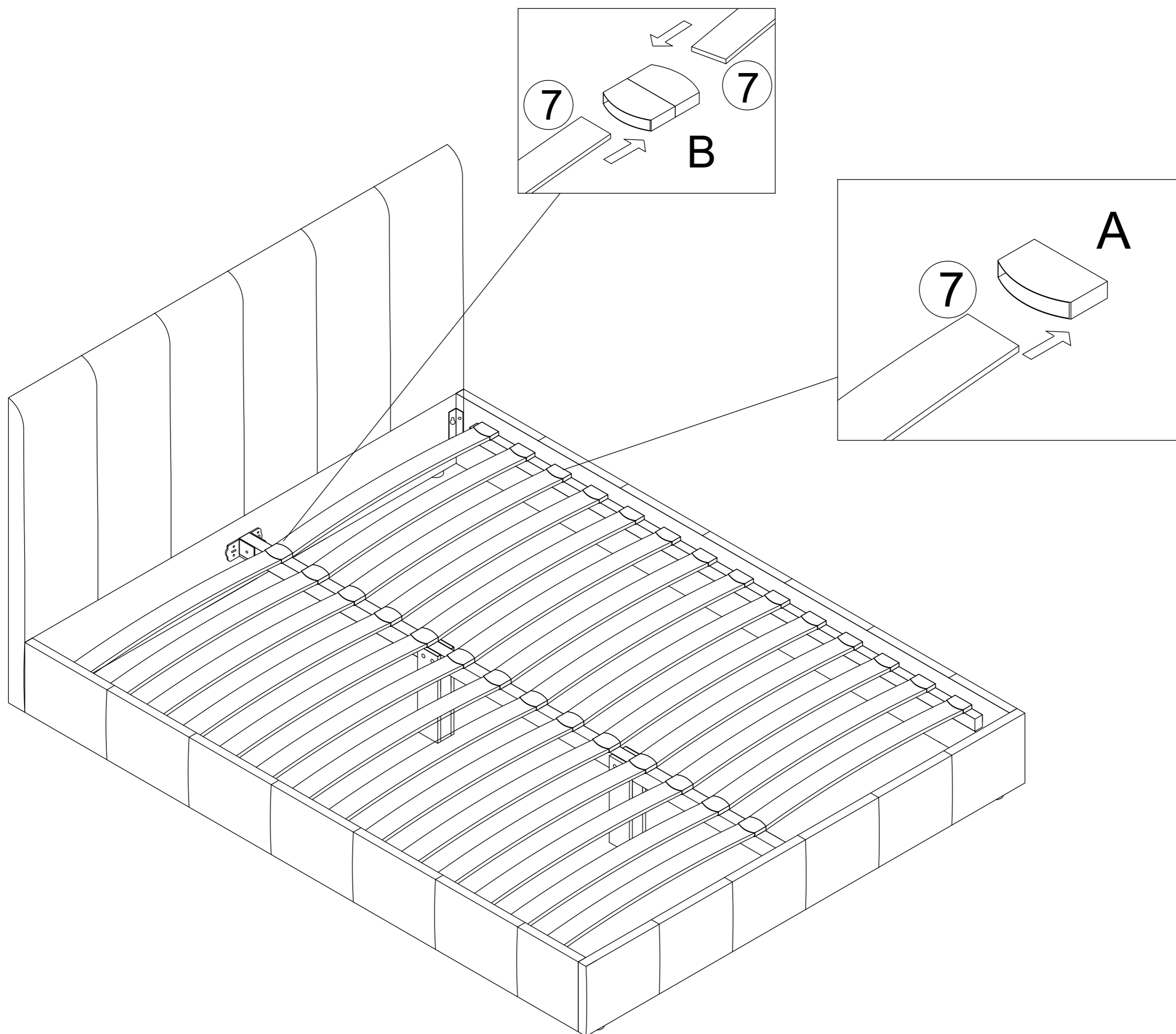

Make sure all slats  
arched like this when  
assembled