

WILTSHIRE KING BED IN A BOX ASSEMBLY INSTRUCTIONS

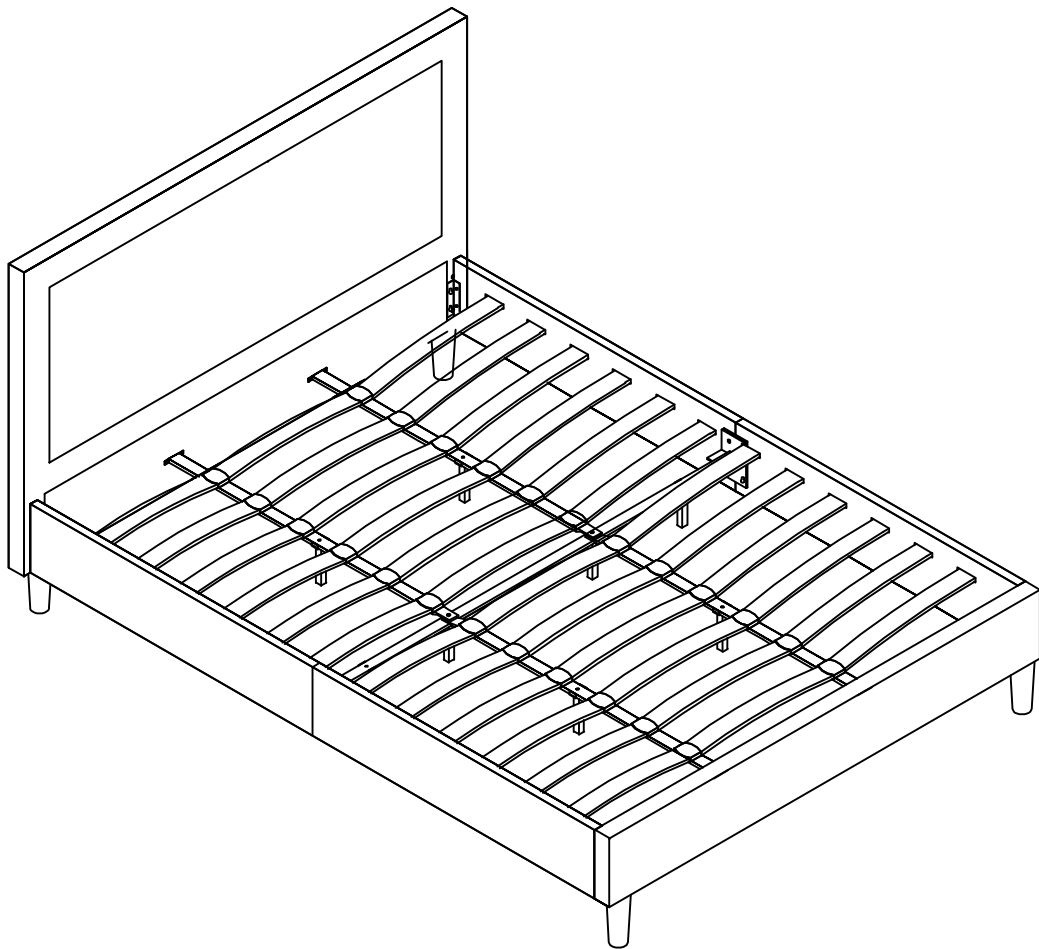

**WILTSHIRE KING BED IS FOR DOMESTIC USE
AND STRICTLY NOT FOR CONTRACT USE.**

Parts list

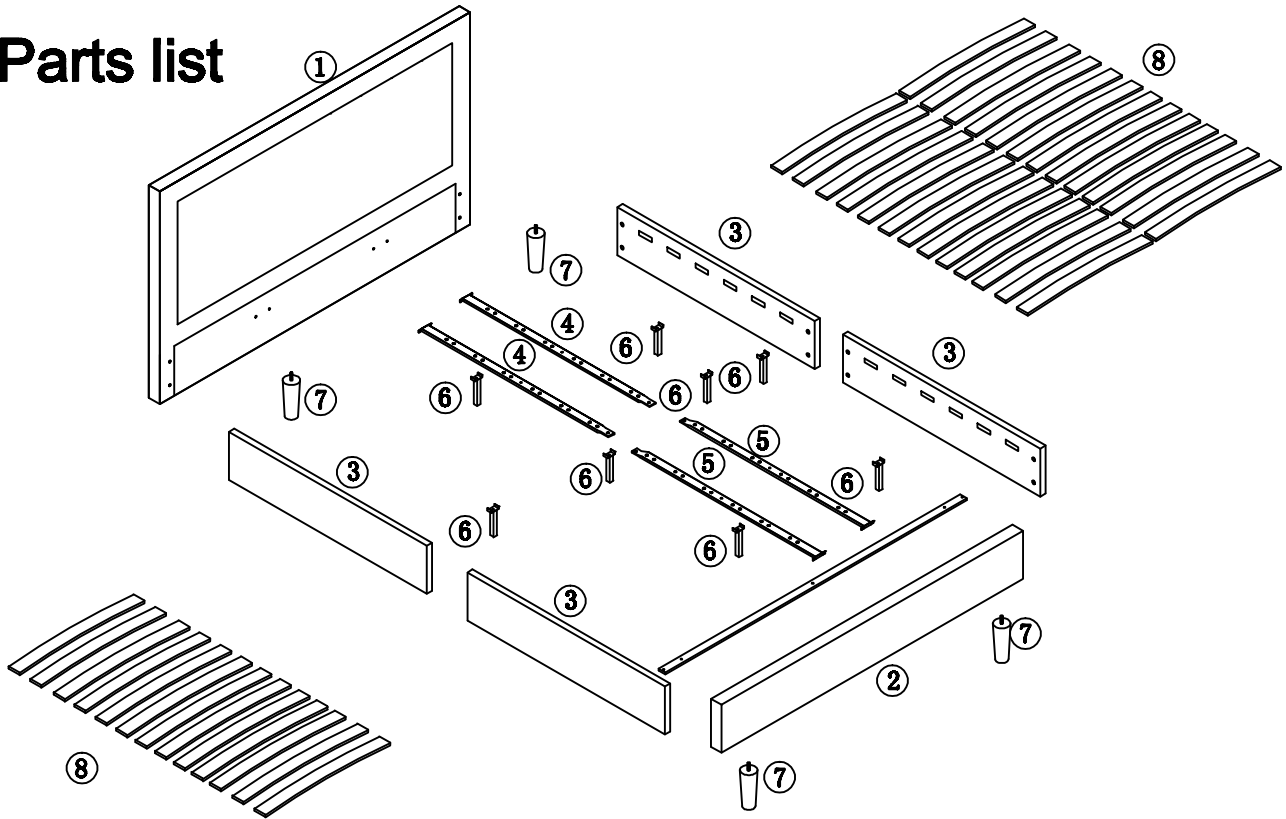

Hardware list

Label	Picture	Description	Qty	Label	Picture	Description	Qty
A		Double Plastic CAP	24	H		Bolt M6x35	2
B		Connection	2	I		Bolt M6x25	8
C		Connection	2	L		Connection Plate Left	2
D		Bolt M8x25	8	R		Connection Plate Right	2
E		Spring Washer	8	N		Bolt M6x20	24
F		Washer M8	12	G		NUT M6	2

TOOL list





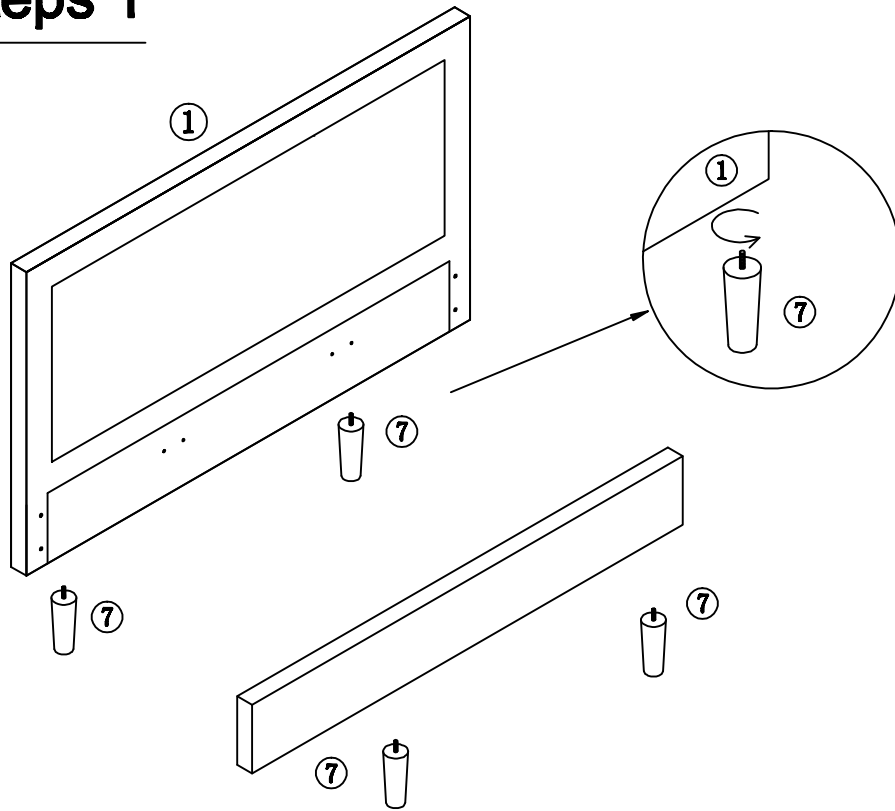

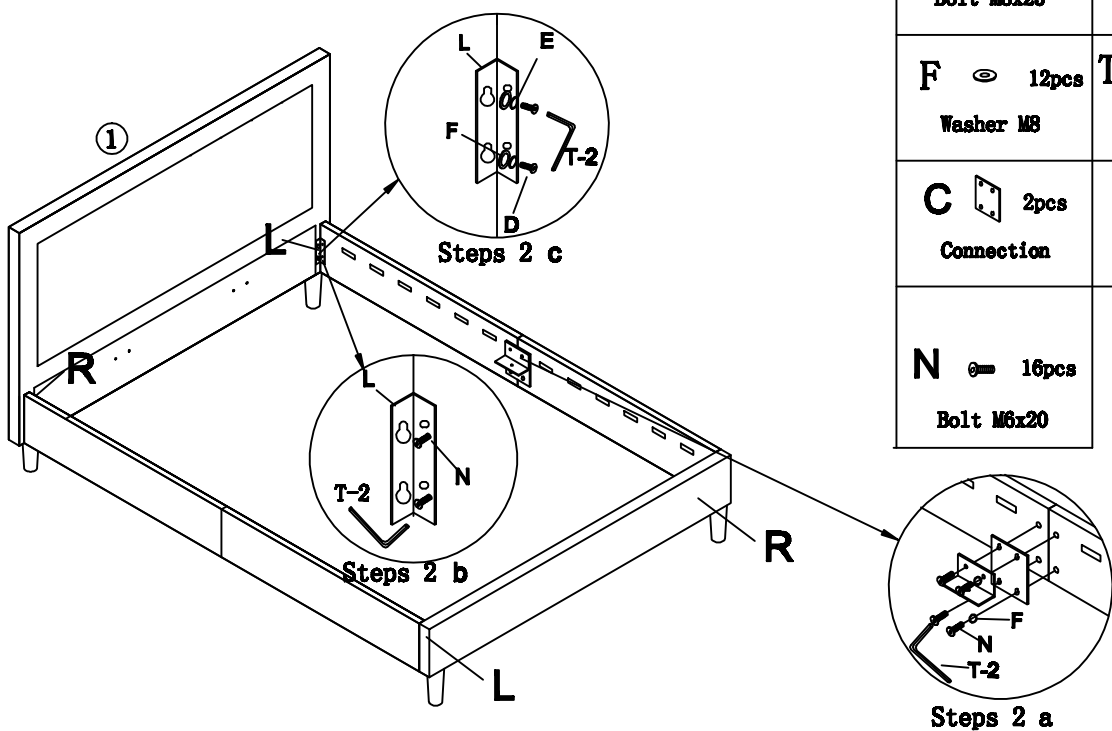

Label	Picture	Description	Qty
T-2		Allen key M5	1
T-3		Allen key M4	1
T-4		SPANNER	1

Steps 1









Steps 2



L  2pcs Connection Plate Left	R  2pcs Connection Plate Right
D  8pcs Bolt M8x25	E  8pcs Spring Washer
F  12pcs Washer M8	T-2  1pcs Allen key 5#
C  2pcs Connection	B  2pcs Connection
N  16pcs Bolt M6x20	

Steps 3

H  2pcs BOLT M6x35	G  2pcs NUT M6	I  8pcs BOLT M6x25
T-3  1pcs Allen key 4#	T-4  1pcs Spanner	N  8pcs Bolt M6x20

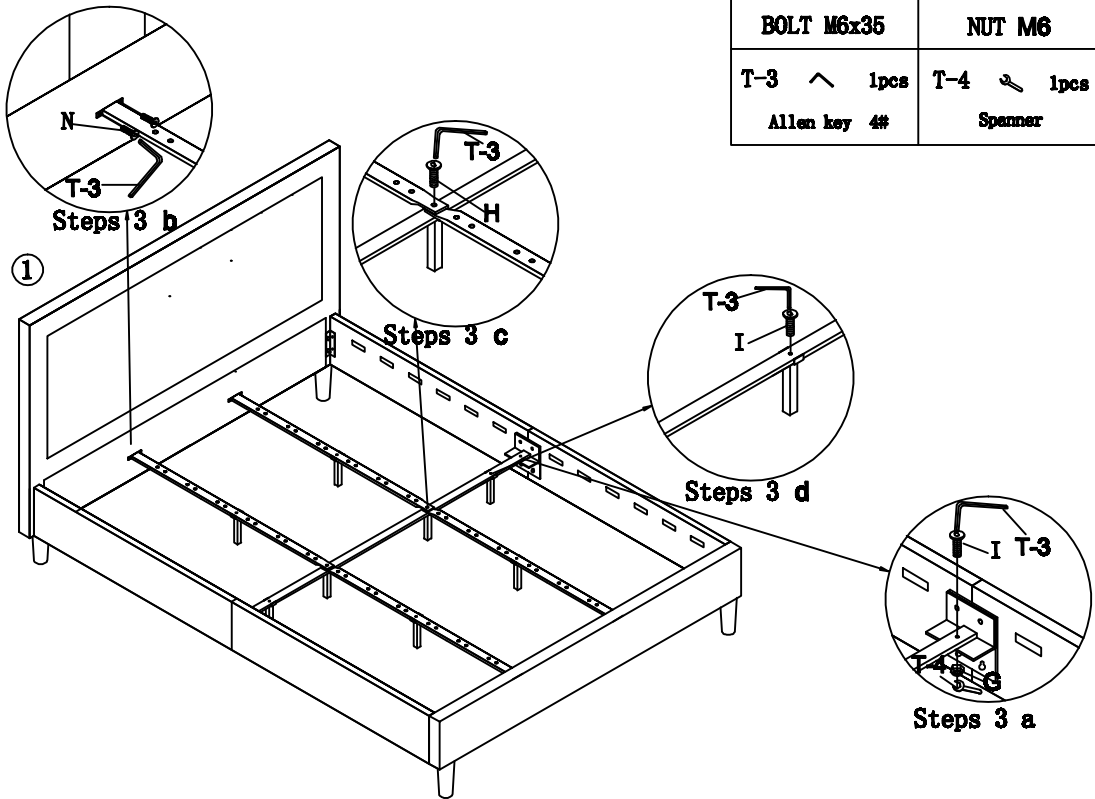

Steps 4

A  24pcs Double Plastic CAP
--

