

FLOATING PLATFORM BED ASSEMBLY INSTRUCTIONS

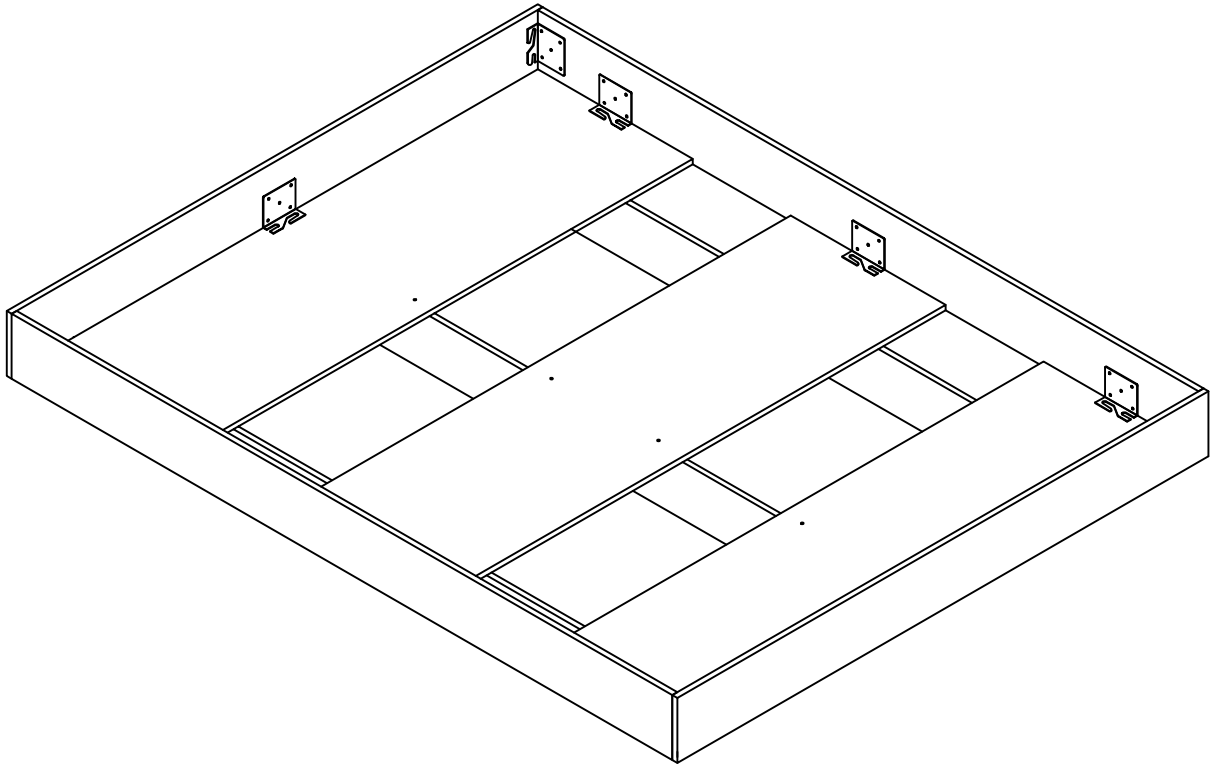

FLOATING PLATFORM BED IS FOR DOMESTIC USE
AND STRICTLY NOT FOR CONTRACT USE.

Parts list

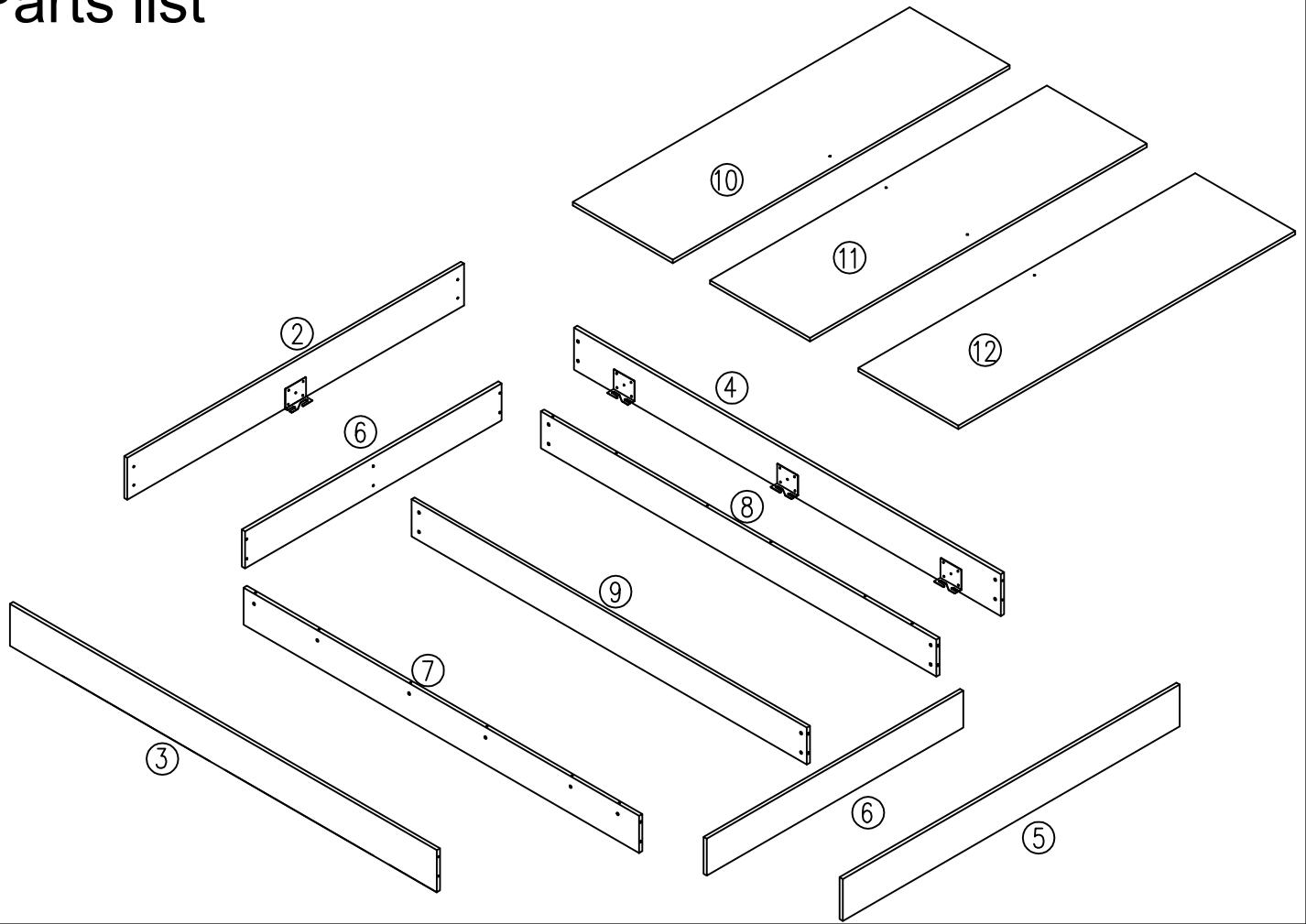

Hardware list

Label	Picture	Description	Qty	Label	Picture	Description	Qty
A		Connecting rod	32	E		Spring Washer	21
B		Connecting buckle	32	F		Washer M6	21
C		Screw 4x35	5	G		Bolt M6x40	5
D		Bolt M6x20	16				

Tool list

Label	Picture	Description	Qty
T-1		Screw driver(not provided)	1
T-2		Allen key M4	1

Step 1

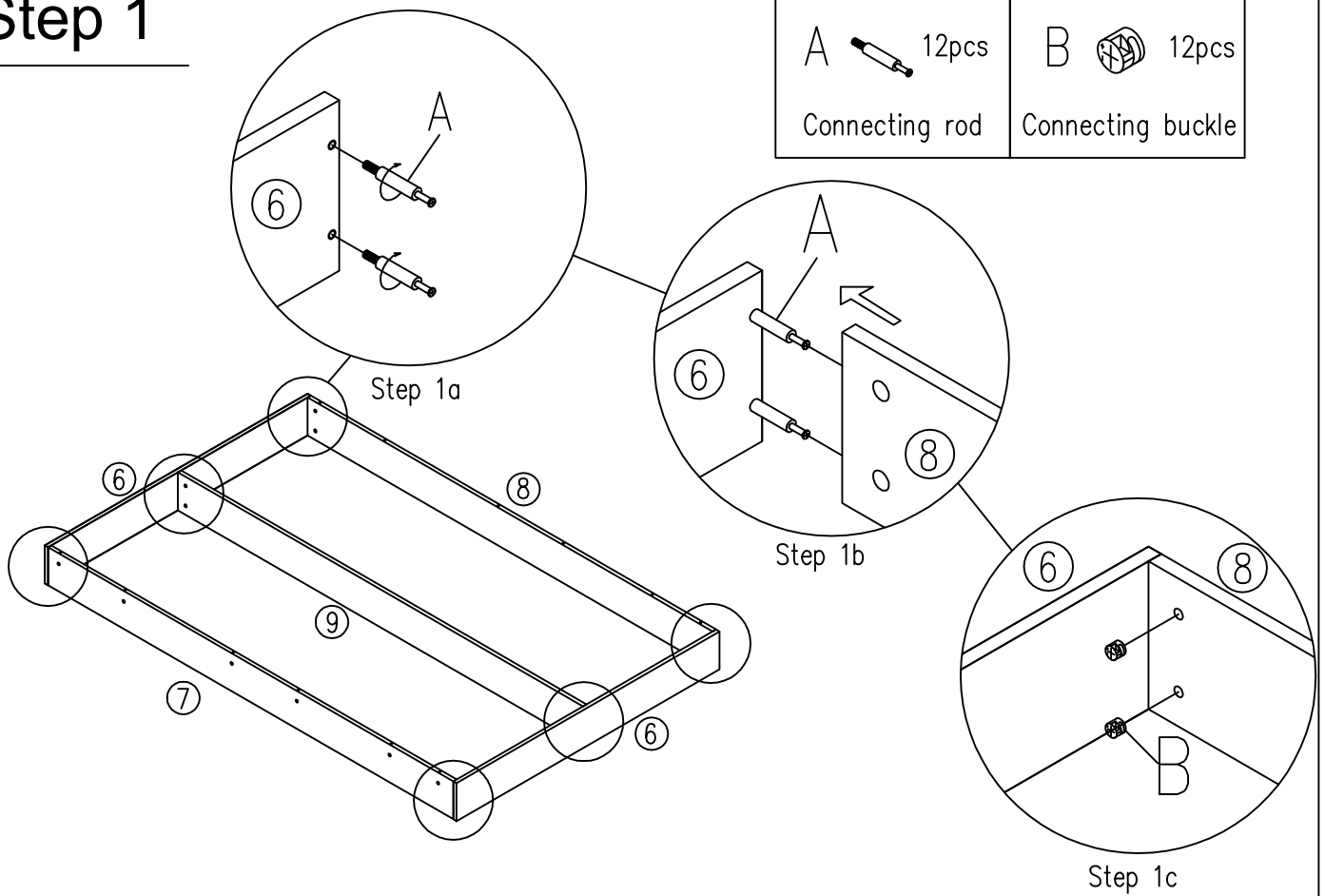

Step 2

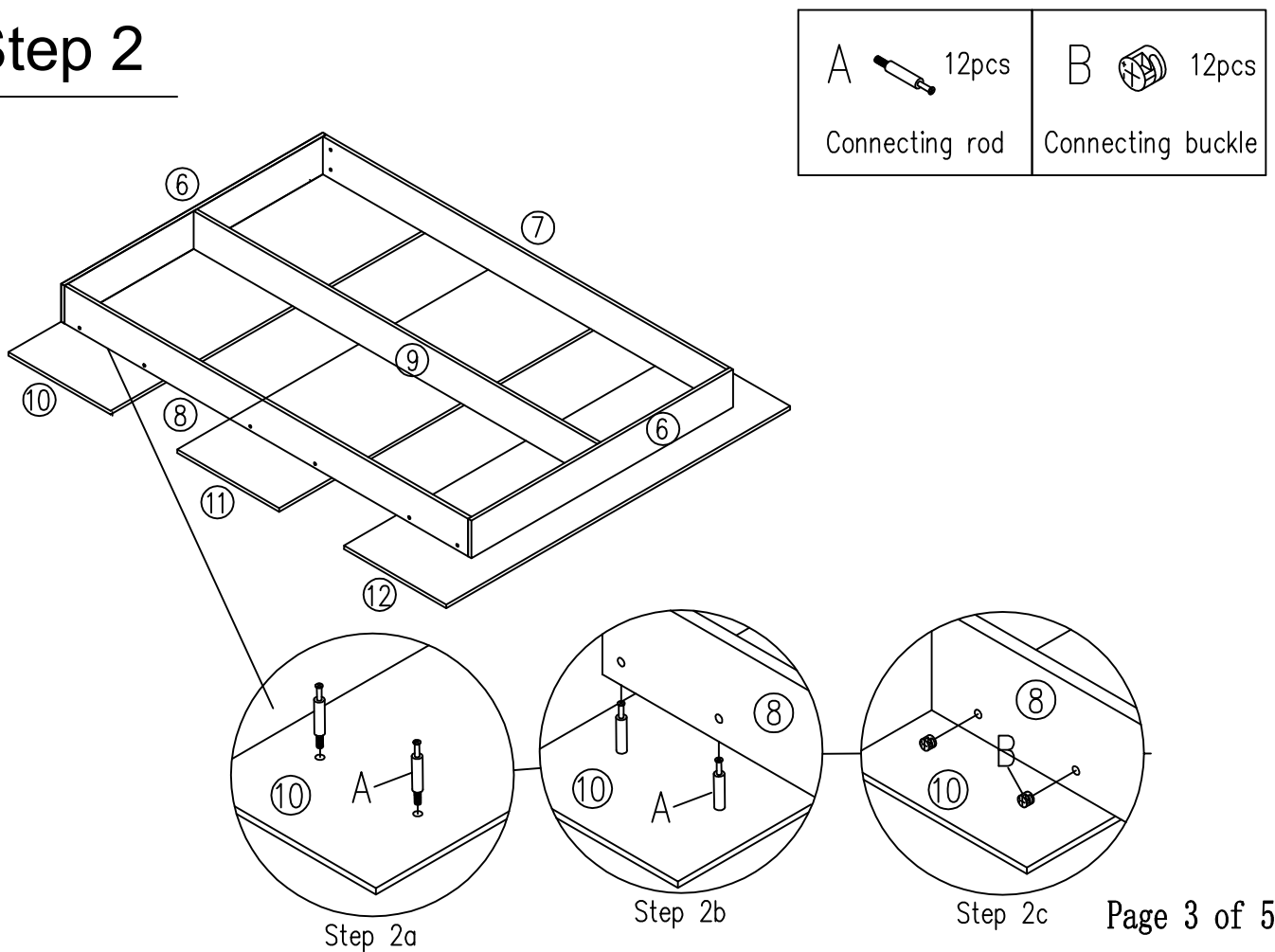

Step 3

C  5pcs
Screw 4x35

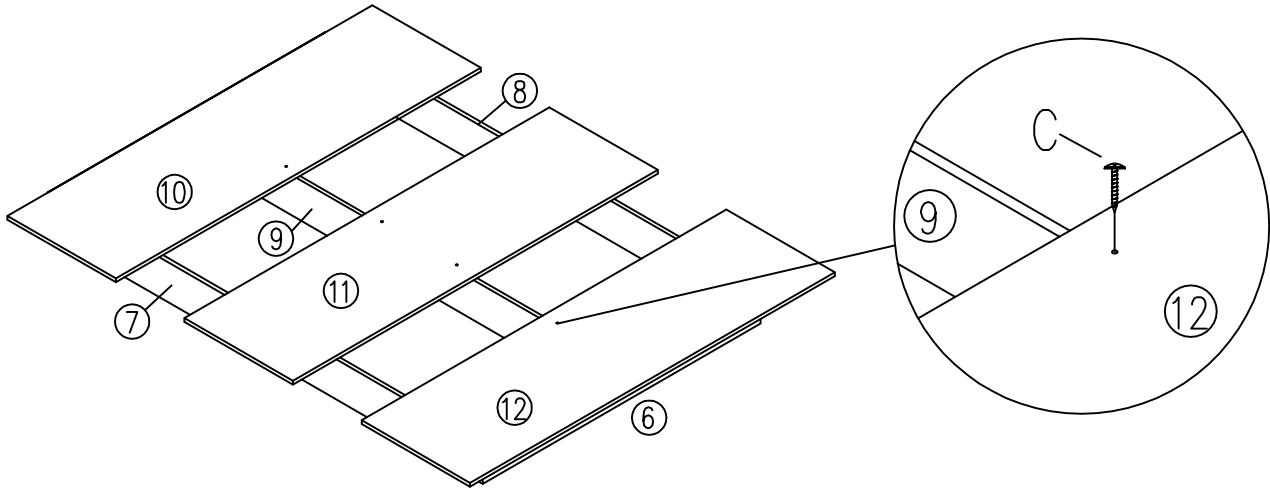

Step 4



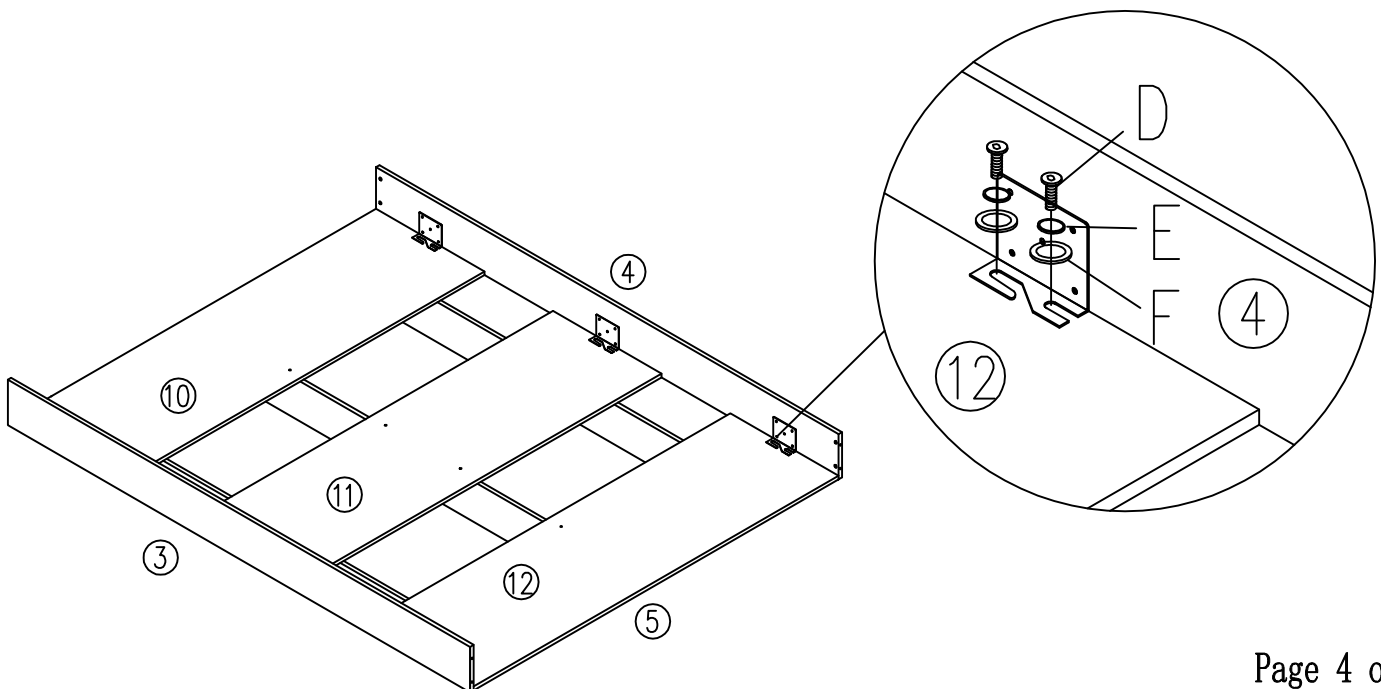

D  12pcs
Bolt M6x20

E  12pcs
Spring Washer

F  12pcs
Washer M6



Step 5

A  8pcs Connecting rod	B  8pcs Connecting buckle
D  4pcs Bolt M6x20	E  4pcs Spring Washer
F  4pcs Washer M6	

