

ST1000/ST1100

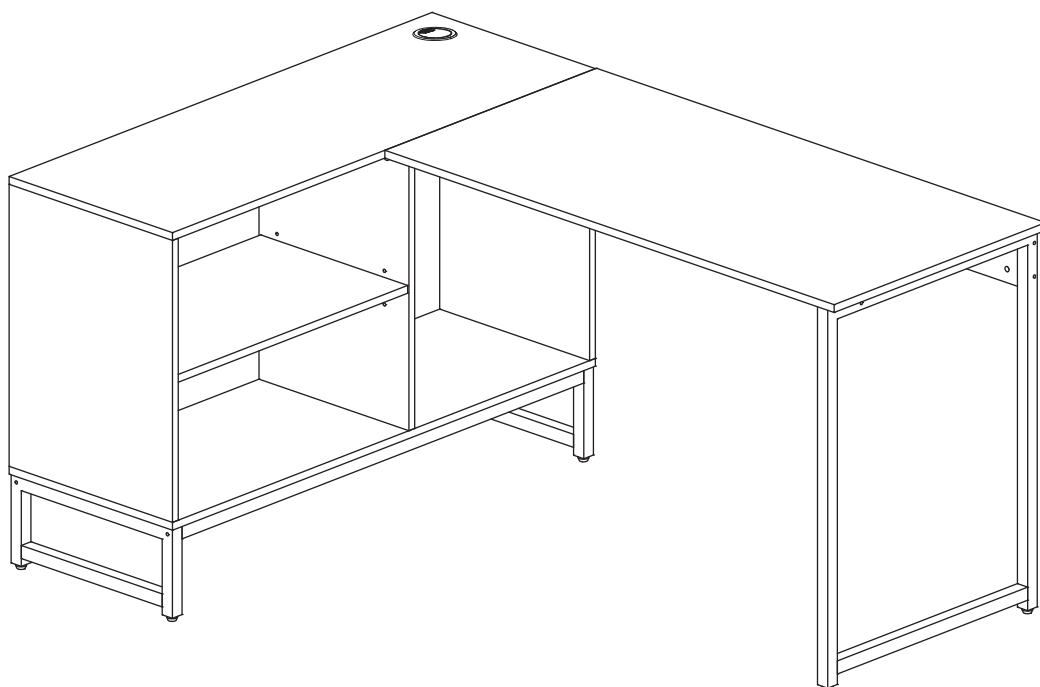

Assembly Instructions

We have designed our furniture with you, the customer in mind. Our clear, easy to follow step by step instructions will guide you through the project from start to finish. Feel confident that this will be a fun and rewarding project. The final product will be a quality piece of furniture that will go together smoothly and give enjoyment.

Assembly Checklist

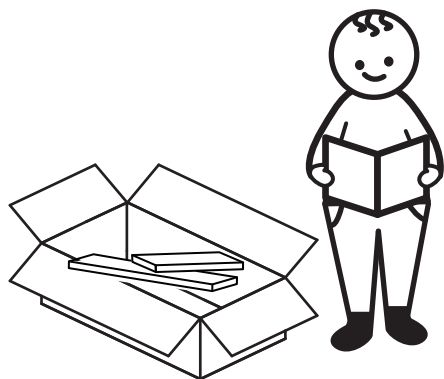

Read through the instructions carefully before you begin.

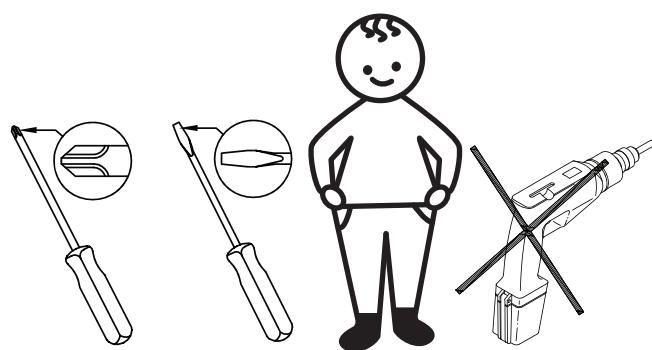

Make sure you have all the required tools. Never use power tools unless instructed.

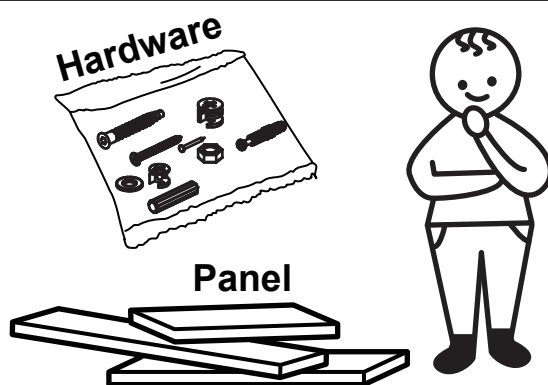

Identify and lay out all of the components before you begin assembly.

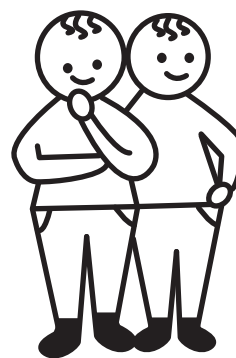

Two people are required to assemble.

Useful Information

! Never use power tools unless specifically instructed. They can damage your components or hardware if used incorrectly.

! The most common mistakes made during assembly are using the wrong hardware or getting components back to front.

! Always use a soft surface (such as carpet or cardboard) when assembling your product to avoid scratching or damaging the surface of the product.

! Bulky items such as wardrobes and bunk beds should be assembled in the room they will be used in as they may not fit through a door once assembled.

! Never use any glue until you are certain that the parts belong together.

! Periodically check and re-tighten all fasteners. Check the product care label or website for product care instructions.

! If you are having any difficulties assembling your product, missing any hardware or components please email us.

! Please see page 2 for any safety requirements or weight restrictions.

QUICKFIT

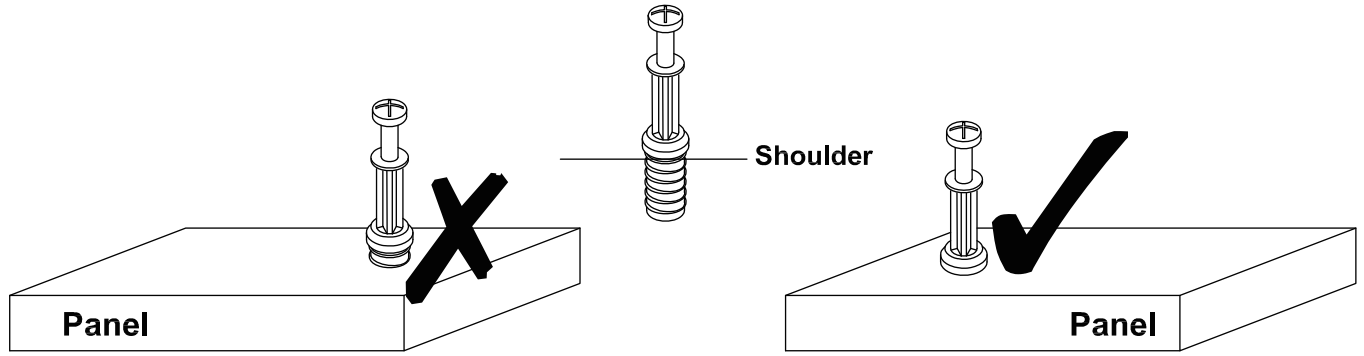

Tighten quickfit until shoulder is flush with panel. Do not overtighten or undertighten.

CAM LOCK

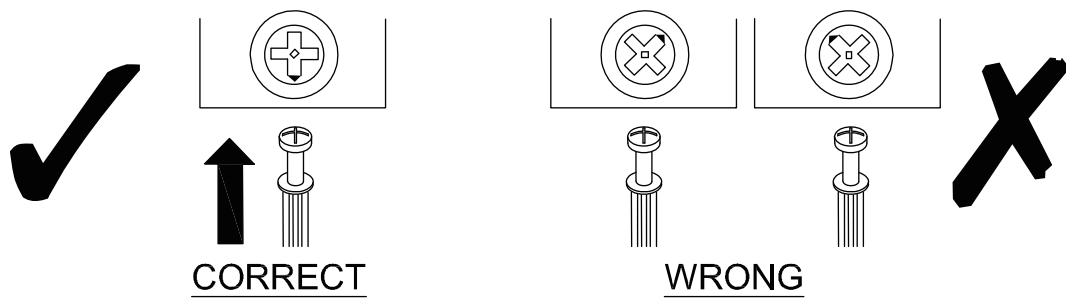





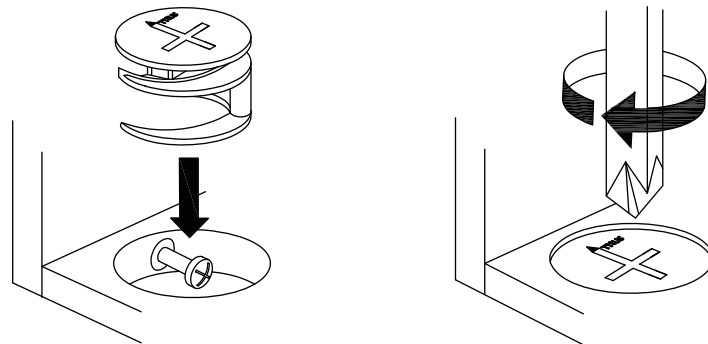



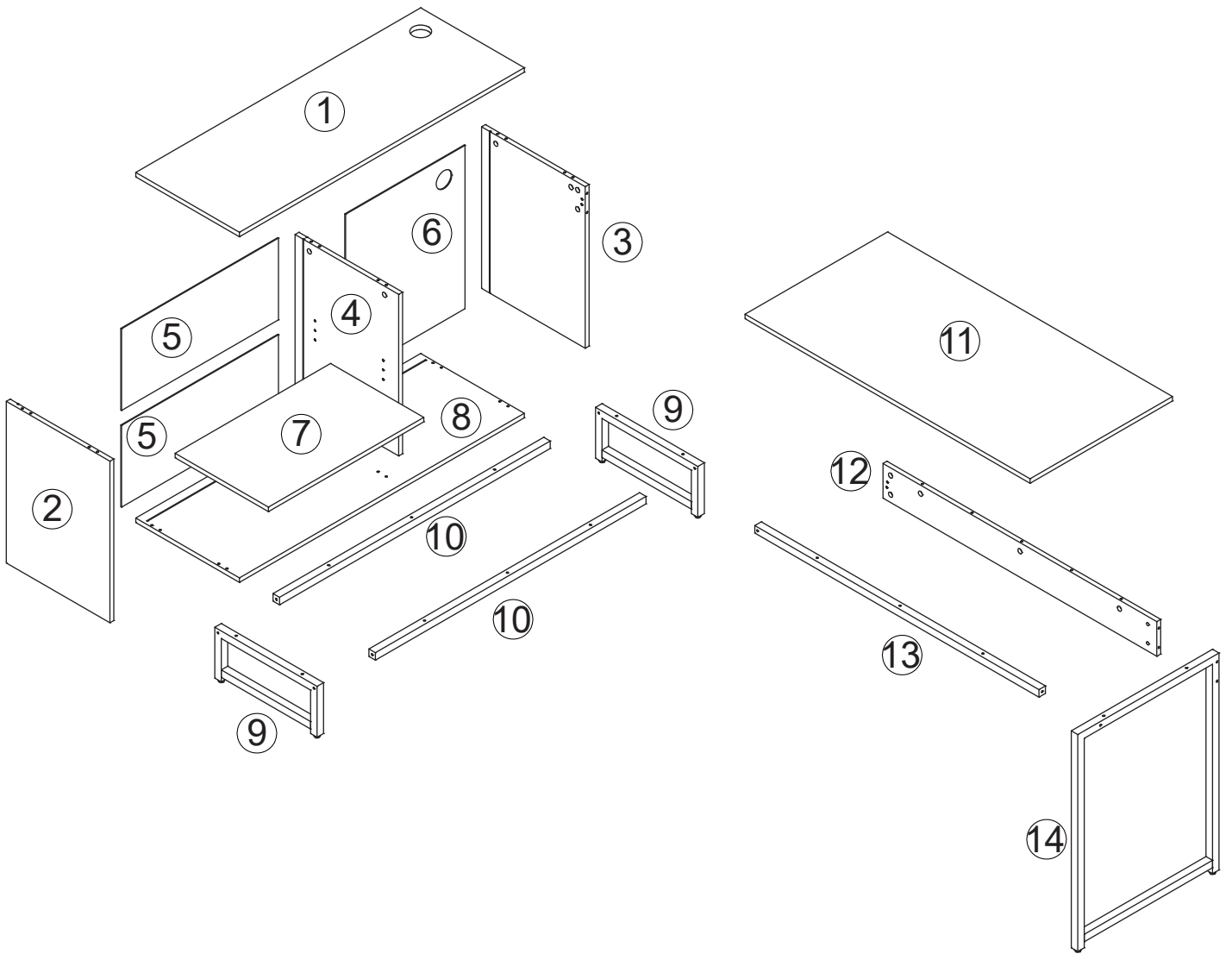

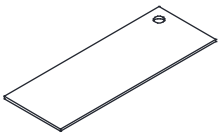
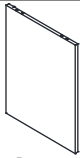

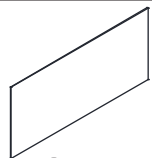
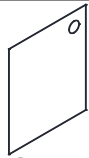
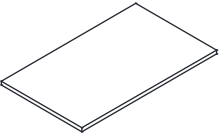
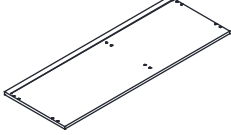
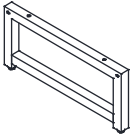
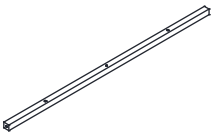
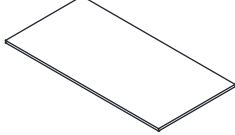
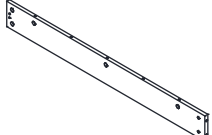
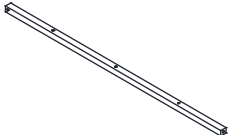
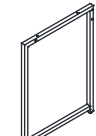

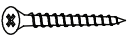

When fitting cam lock, ensure starting position is correct before you insert connecting quickfit.

Quickfit head should be in the centre of the cam lock when the two panels are joined. Cam lock should be inserted before quickfit.

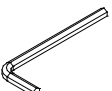

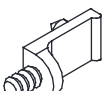
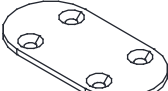
Turn cam lock clockwise to tighten.

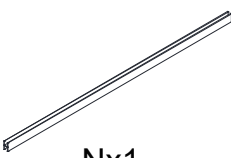

| | | | | | |
|--|--|--|--|--|---|
|  ① x1 |  ② x1 |  ③ x1 |  ④ x1 |  ⑤ x2 |  ⑥ x1 |
|  ⑦ x1 |  ⑧ x1 |  ⑨ x2 |  ⑩ x2 |  ⑪ x1 |  ⑫ x1 |
|  ⑬ x1 |  ⑭ x1 | | | | |
|  Ax9 |  Bx13 |  Cx14 |  Dx6 |  (Ø6x35mm) Ex16 |  (Ø6x50mm) Fx7 |
|  Gx2 |  Hx1 |  Ix2 |  Jx4 |  Kx3 |  Lx12 |
|  Mx8 |  Nx1 |  Ox1 | | | |

Step 1

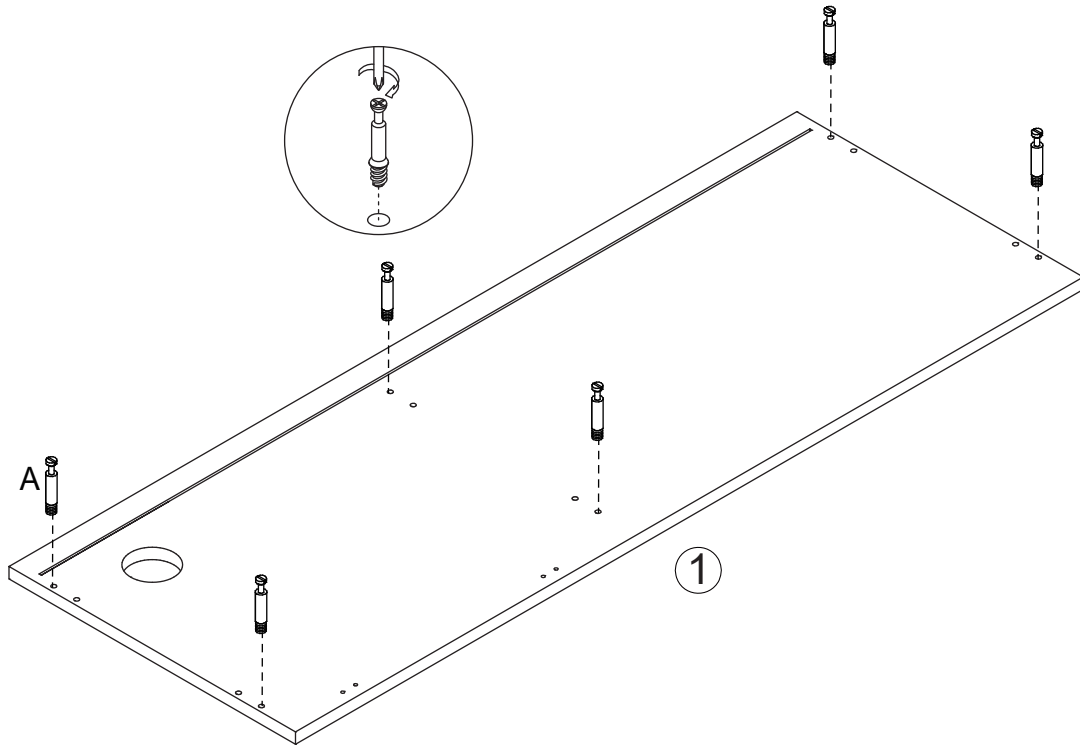

6xA



Step 2

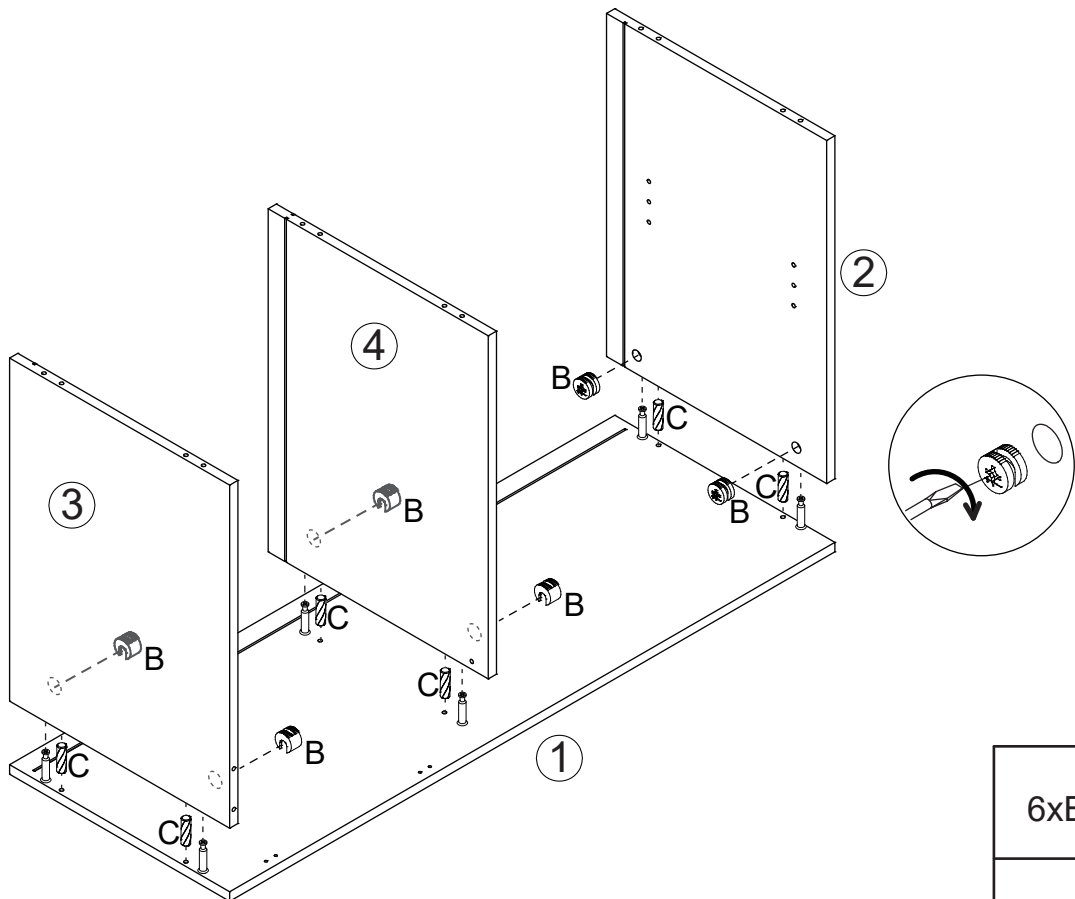

6xB



6xC



Step 3

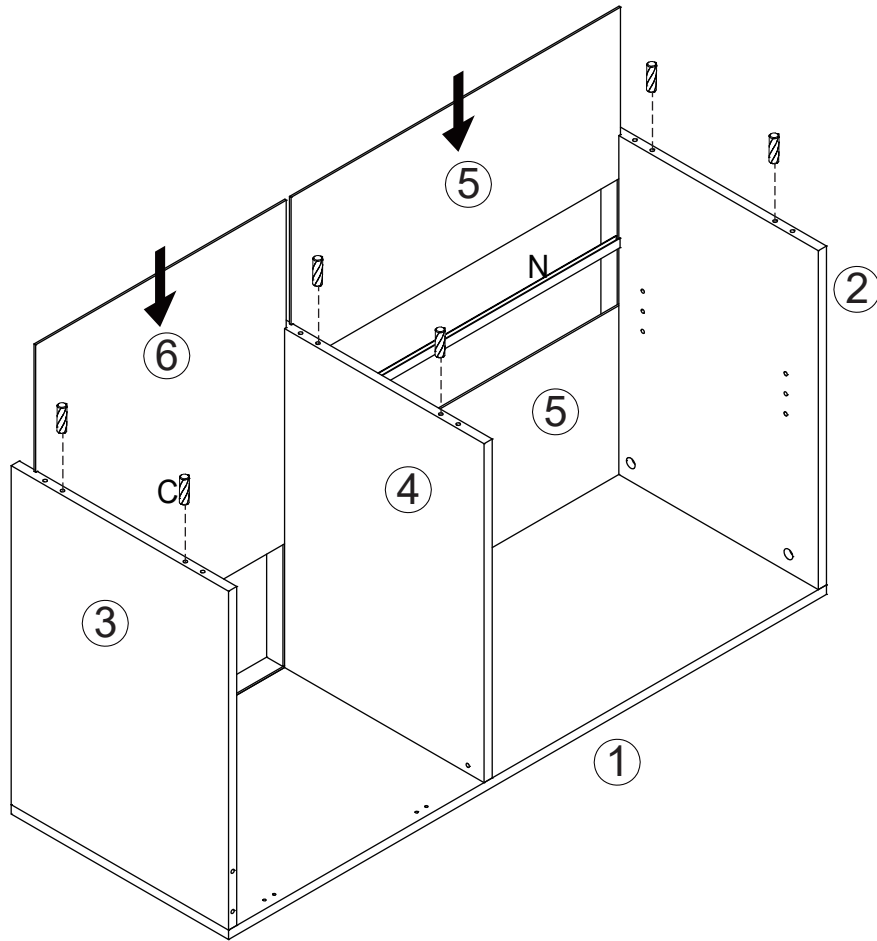

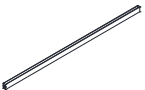
| | |
|-----|---|
| 6xC |  |
| 1xN |  |

Step 4

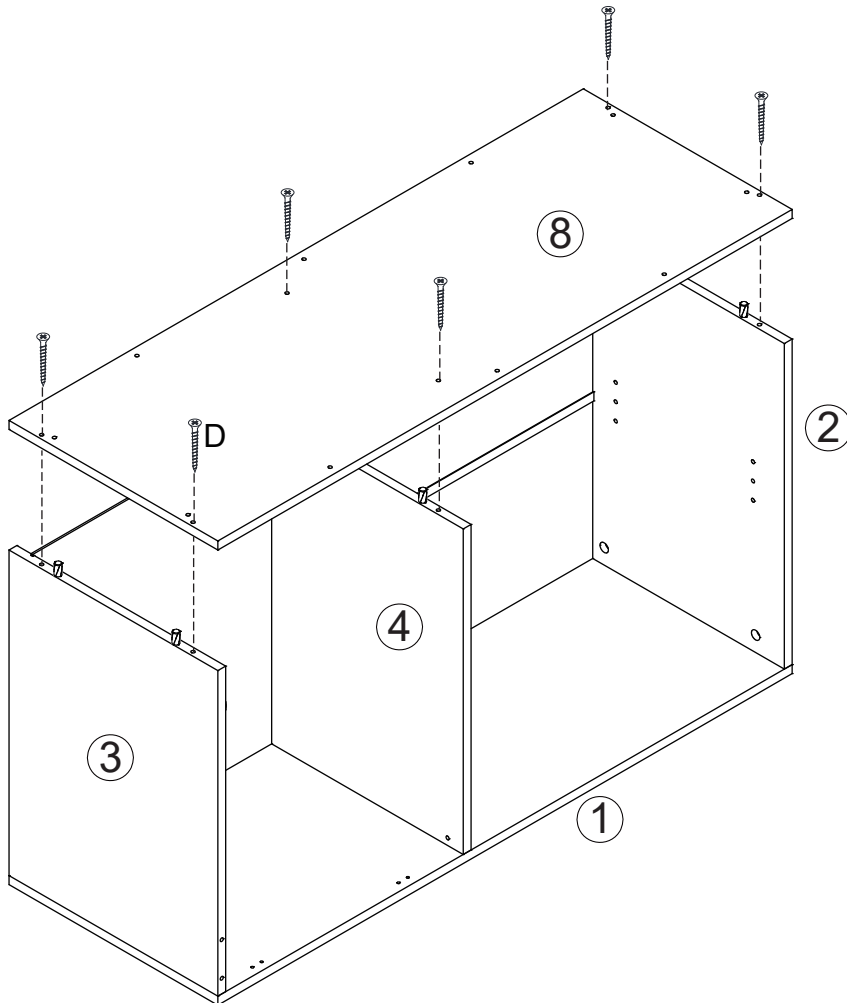

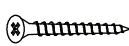
| | |
|-----|---|
| 6xD |  |
|-----|---|

Step 5

 Do not tighten ANY bolts until entire unit is set up!

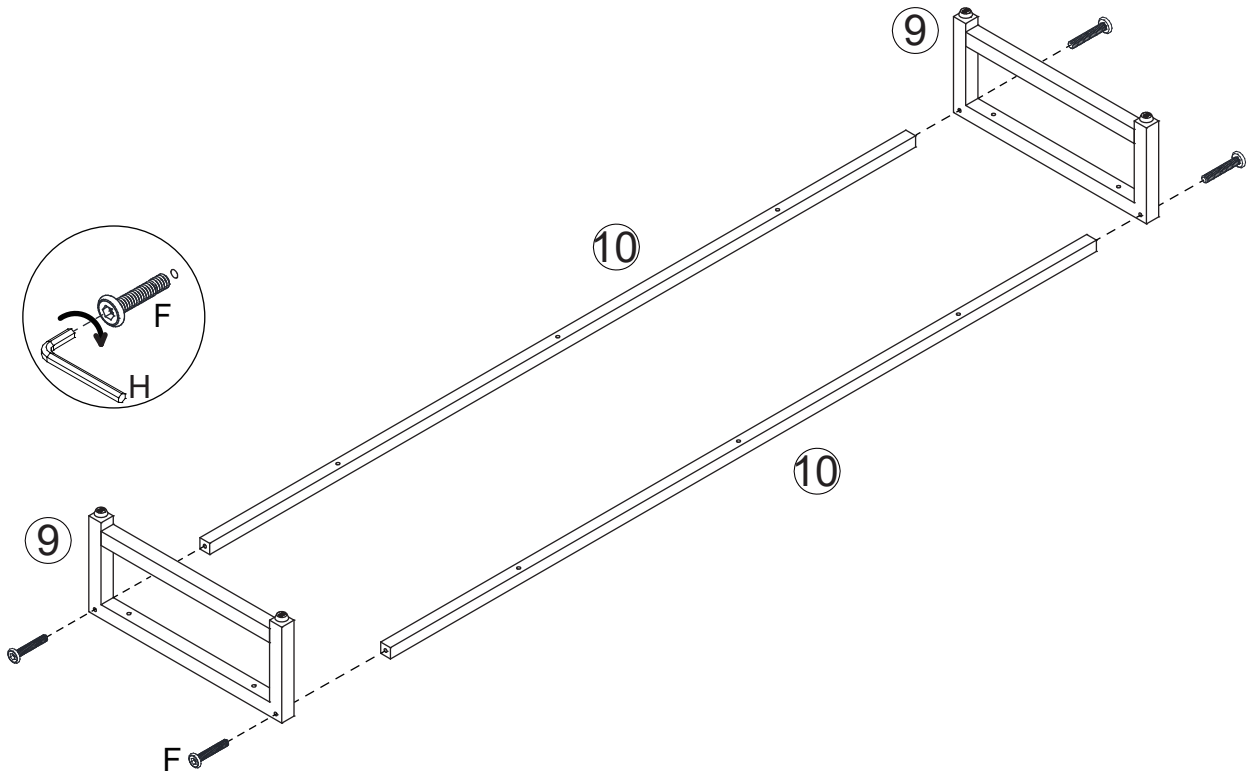

4xF



Step 6

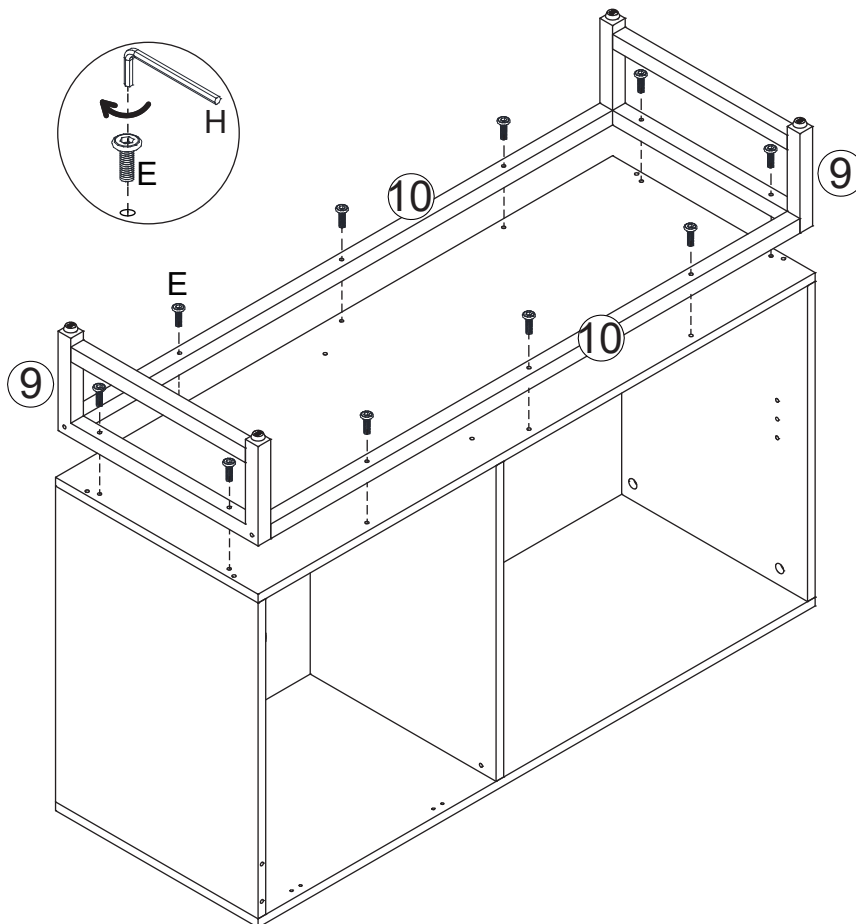



 Gently Tighten All Bolts.

10xE



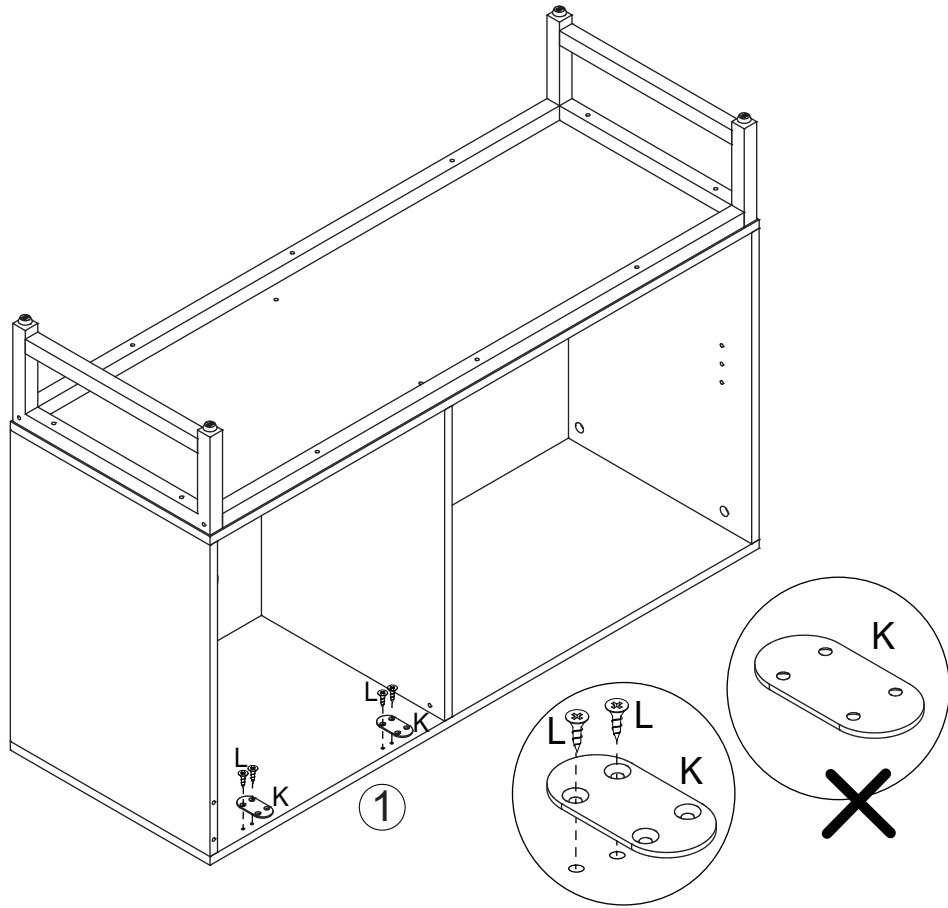

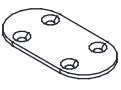
Step 7

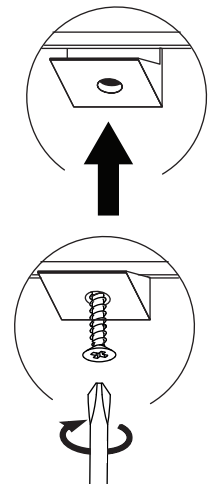
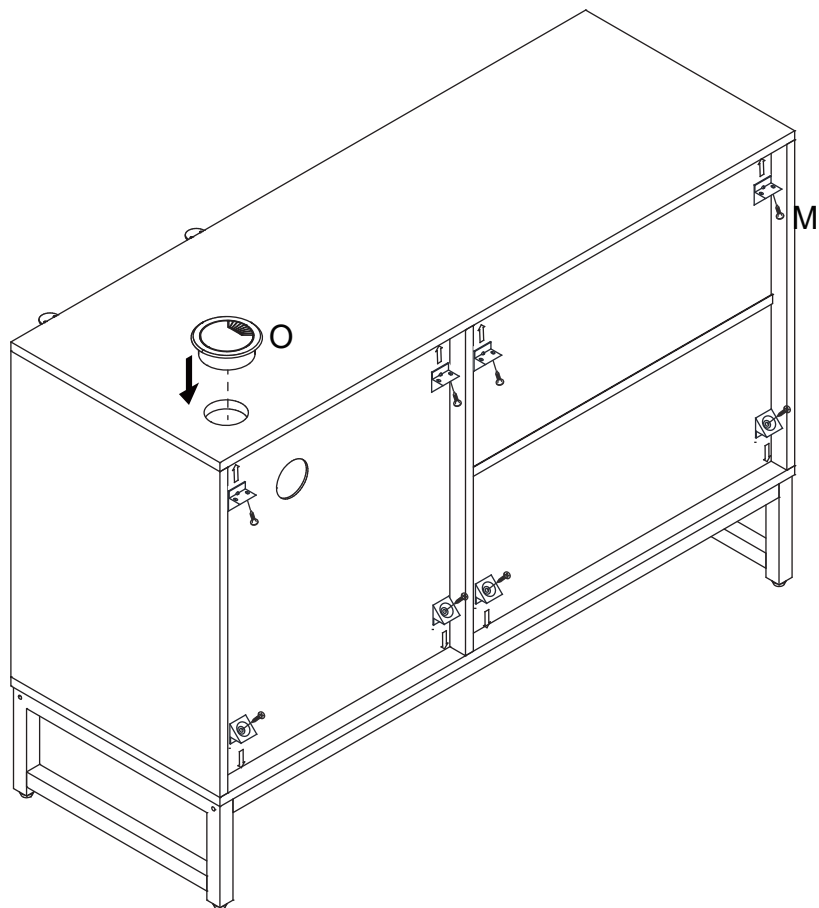

| | |
|-----|---|
| 2xK |  |
| 4xL |  |

Step 8



| | |
|-----|---|
| 8xM |  |
| 1xO |  |

Step 9

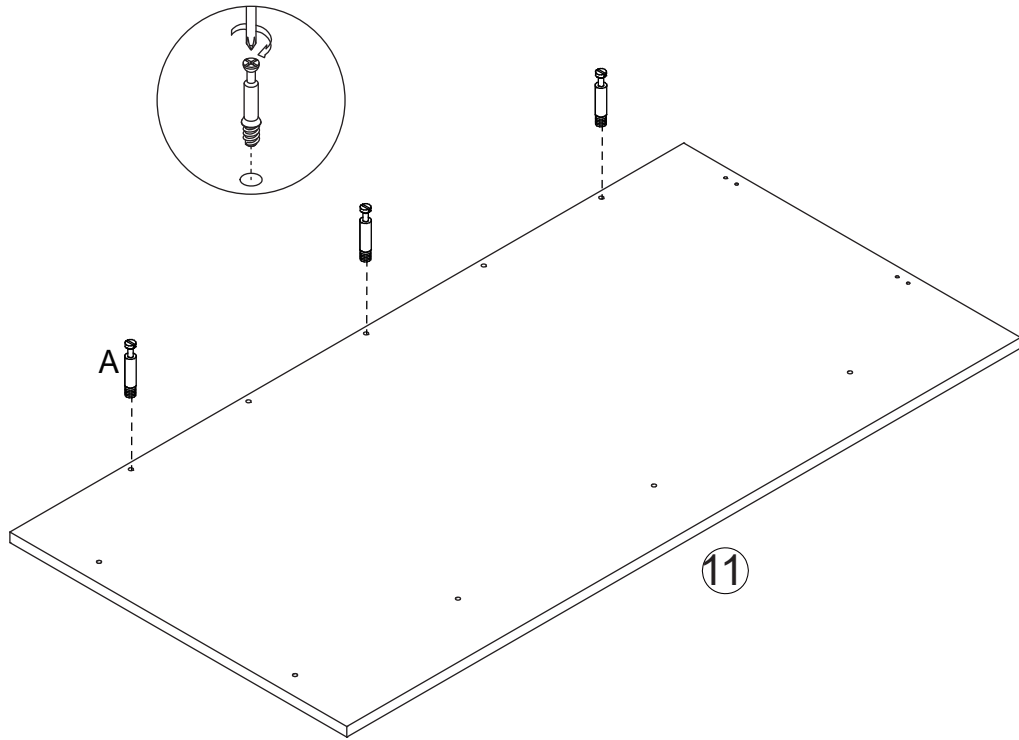

3xA



Step 10

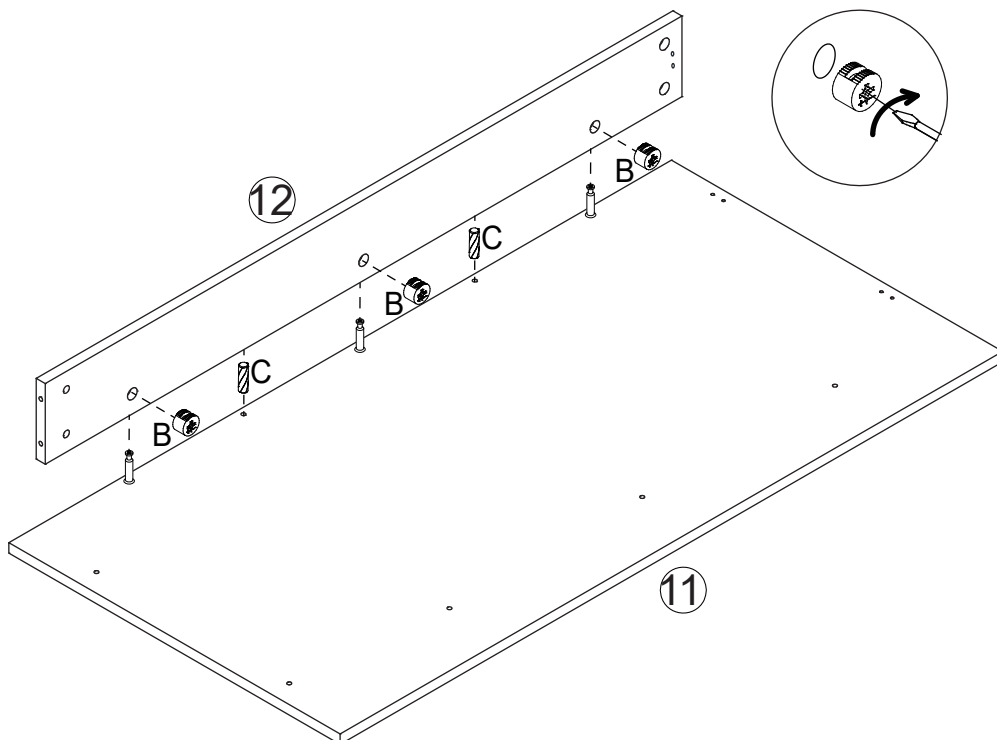

3xB



2xC



Step 11

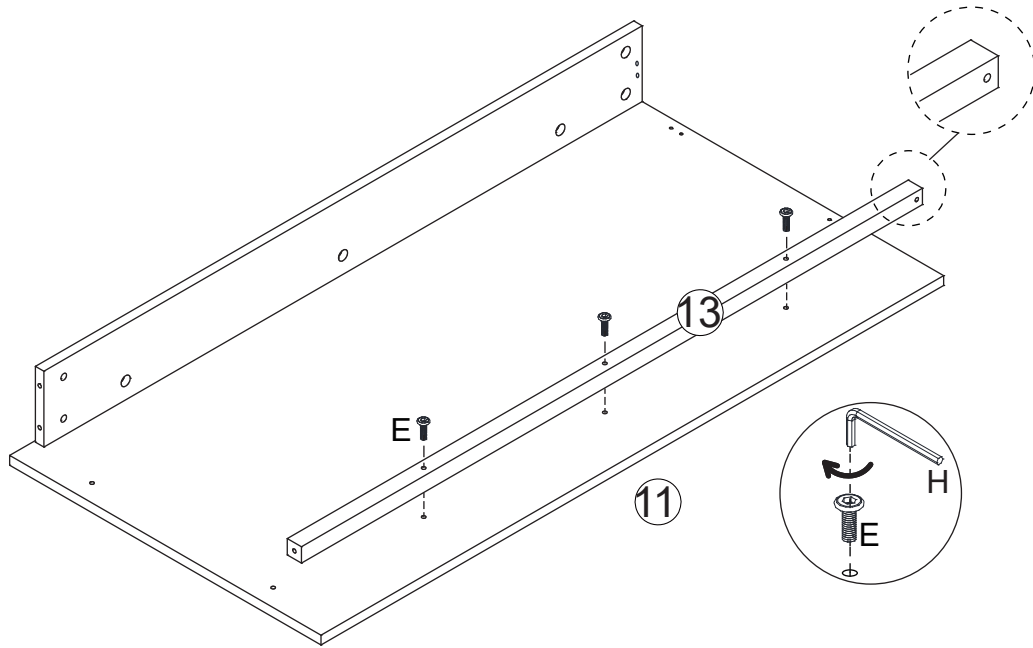

3xE



Step 12

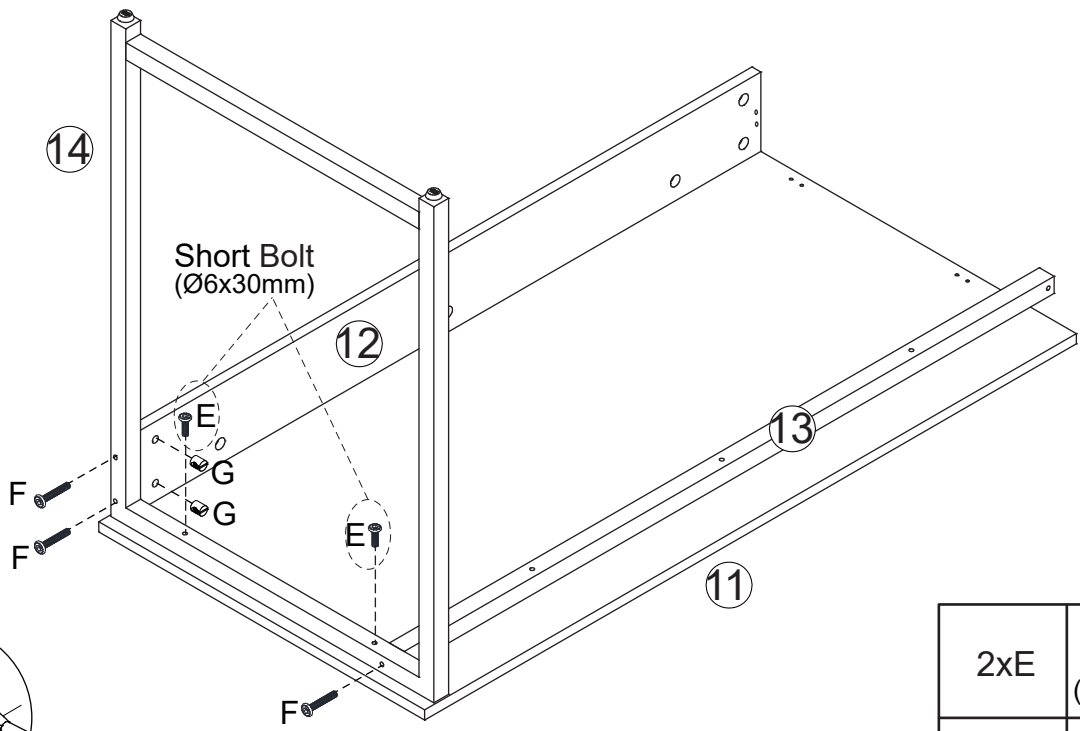

2xE



3xF



2xG

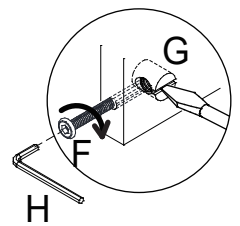

Step 13

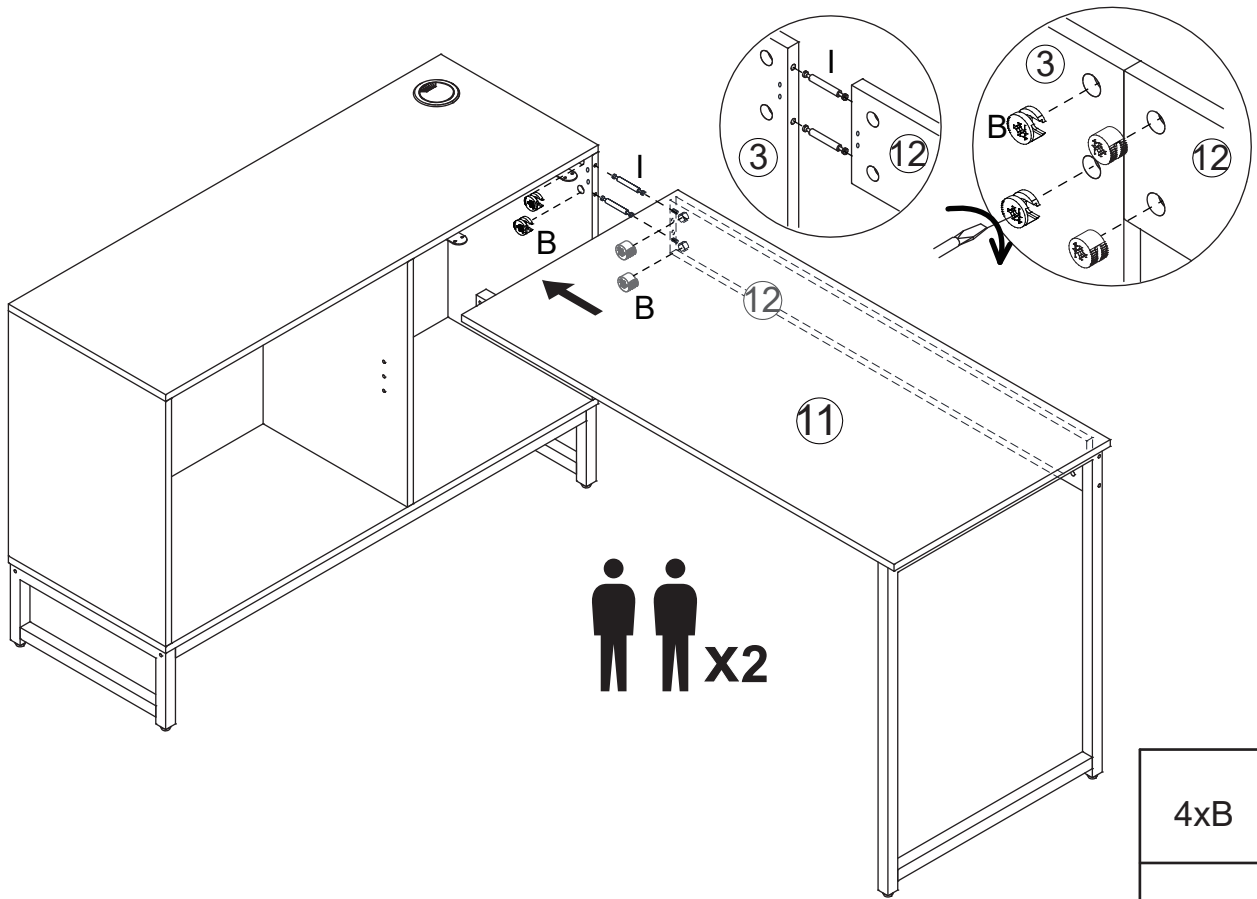

| | |
|-----|--|
| 4xB | |
| 2xI | |

Step 14

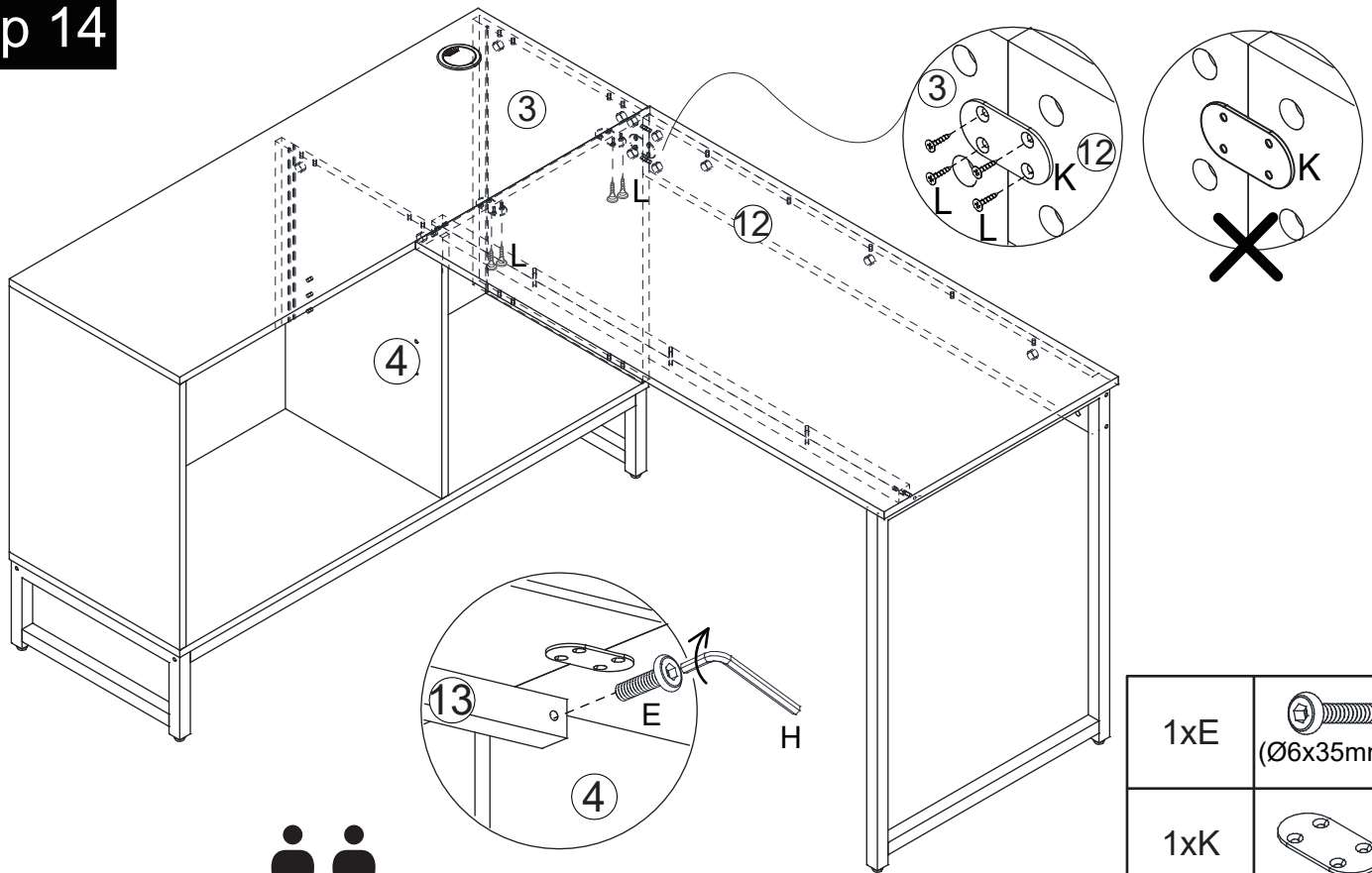

| | |
|-----|--|
| 1xE | |
| 1xK | |
| 8xL | |

Step 15

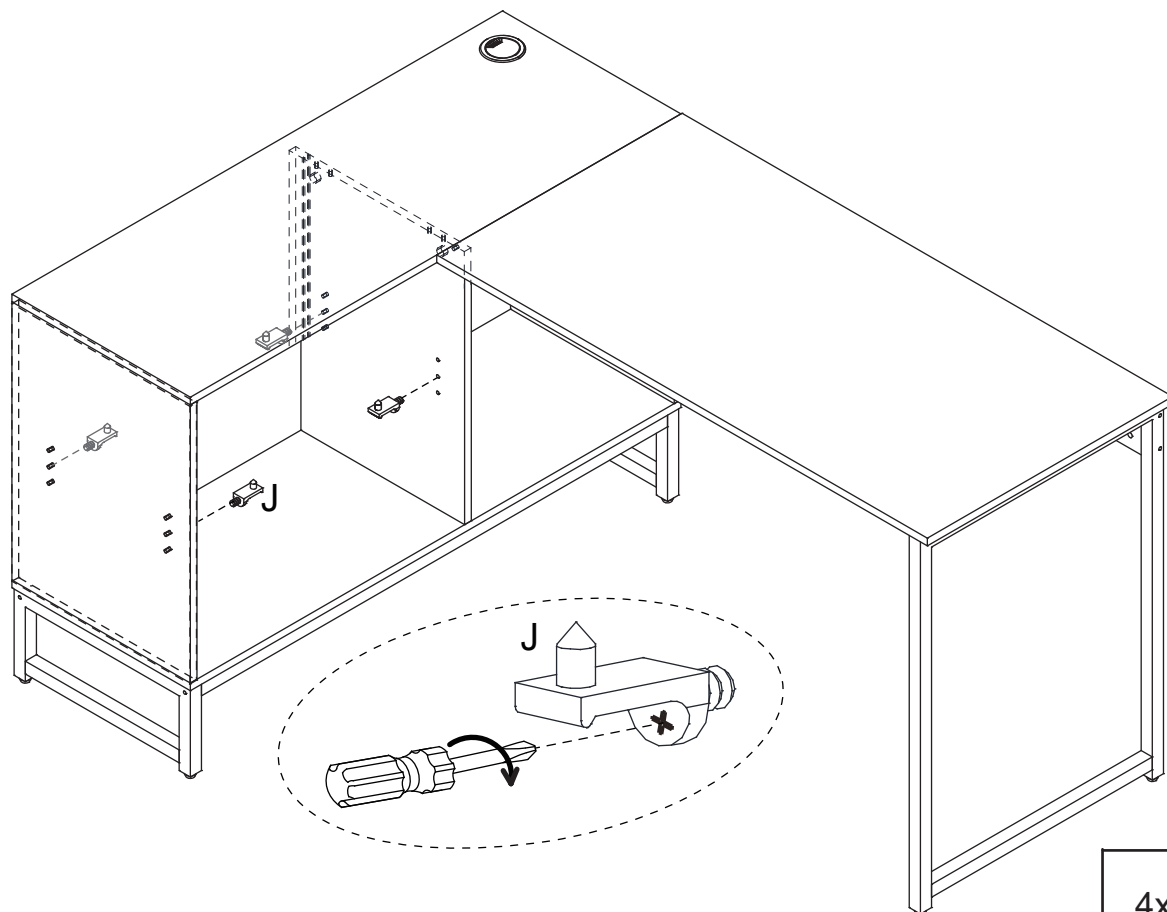

Step 16

