



65 X 65 X 35 CM



READ THE MANUAL
It will help you get the best out of your product.
ANY QUESTIONS?
Call (03) 9904 2900

Assembly instructions

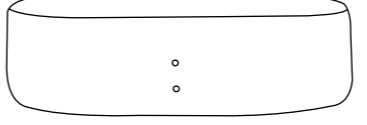
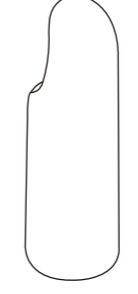
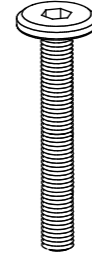
Hardware list

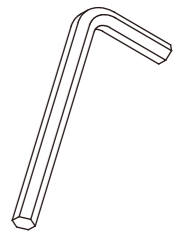
A  x1	B  x3	C  x6	D  x6	E  x6	F  x1
---	---	---	---	---	---

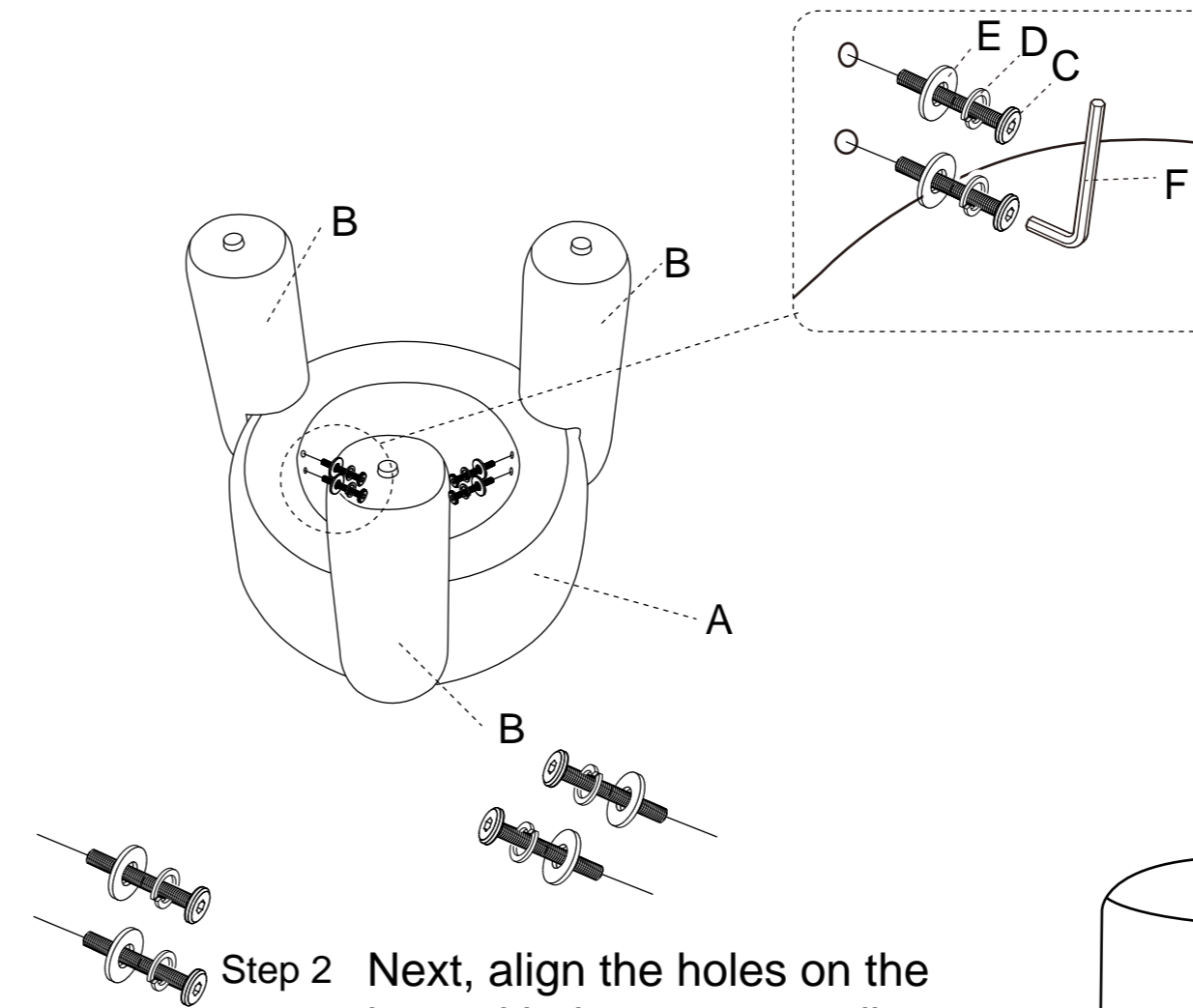
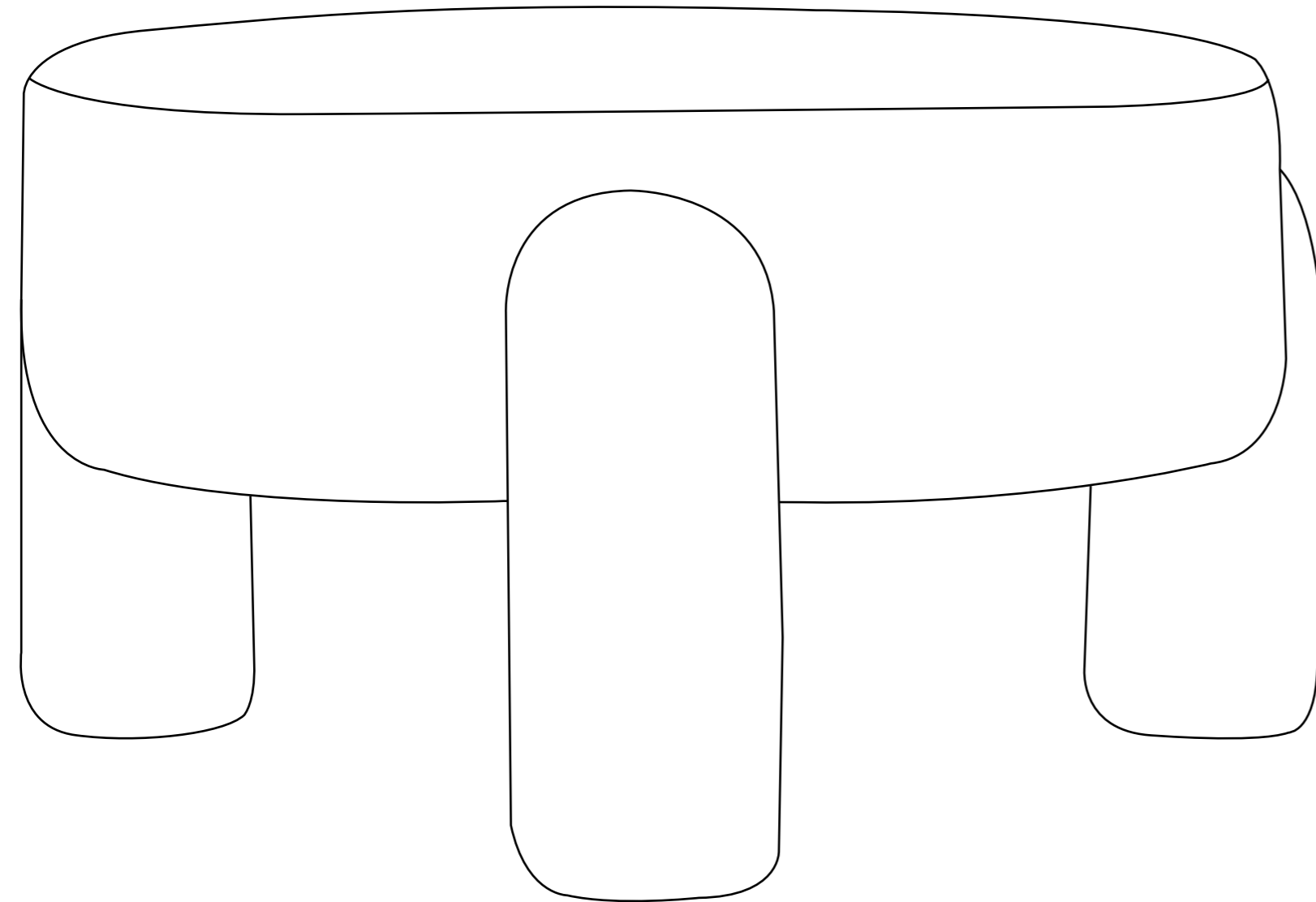

Step 1 First, arrange parts E and D in the sequence shown in the picture and place them over screw C.

Step 2 Next, align the holes on the legs with the corresponding holes on the body. Insert the combined assembly of E, D, and C (referred to as EDC for brevity) into the aligned holes. Finally, tighten the screws with Wrench (F).

