

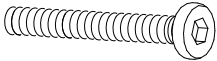

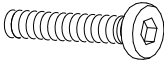

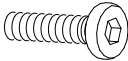

<p>A x 14</p>  <p>M8×70mm</p>	<p>B x 12</p>  <p>M8×45 mm</p>	<p>C x 9</p>  <p>M6×35 mm</p>	<p>D x 8</p>  <p>M8×15 mm</p>
<p>E x 12</p>  <p>M8</p>	<p>F x 1</p>  <p>M5</p>	<p>G x 1</p> 	<p>H x 4</p> 
<p>I x 4</p>  <p>M8×35 mm</p>	<p>J x 1</p>  <p>M4</p>	<p>K x 2</p>  <p>M6×50 mm</p>	<p>L x 2</p>  <p>M6×40 mm</p>

① X1

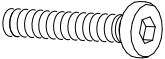

② X1

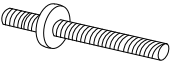
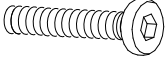
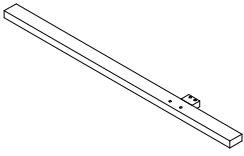
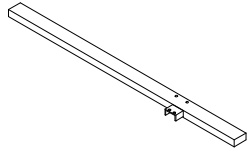

③ X1



④ X1



⑤ X2

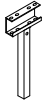

⑥ X2



⑦ X2

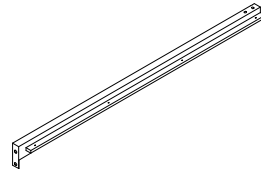

⑧ X2

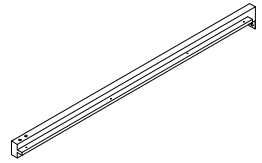

⑨ X3

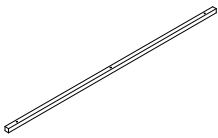

⑩ X3

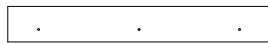

⑪ X4

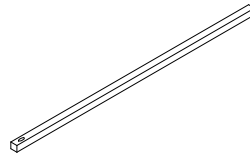

⑫ X2

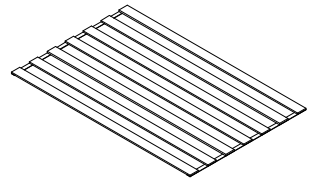

⑬ X2

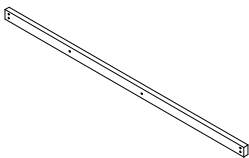

⑭ X2

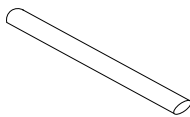

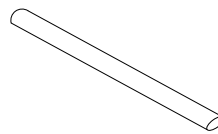

⑮ X1

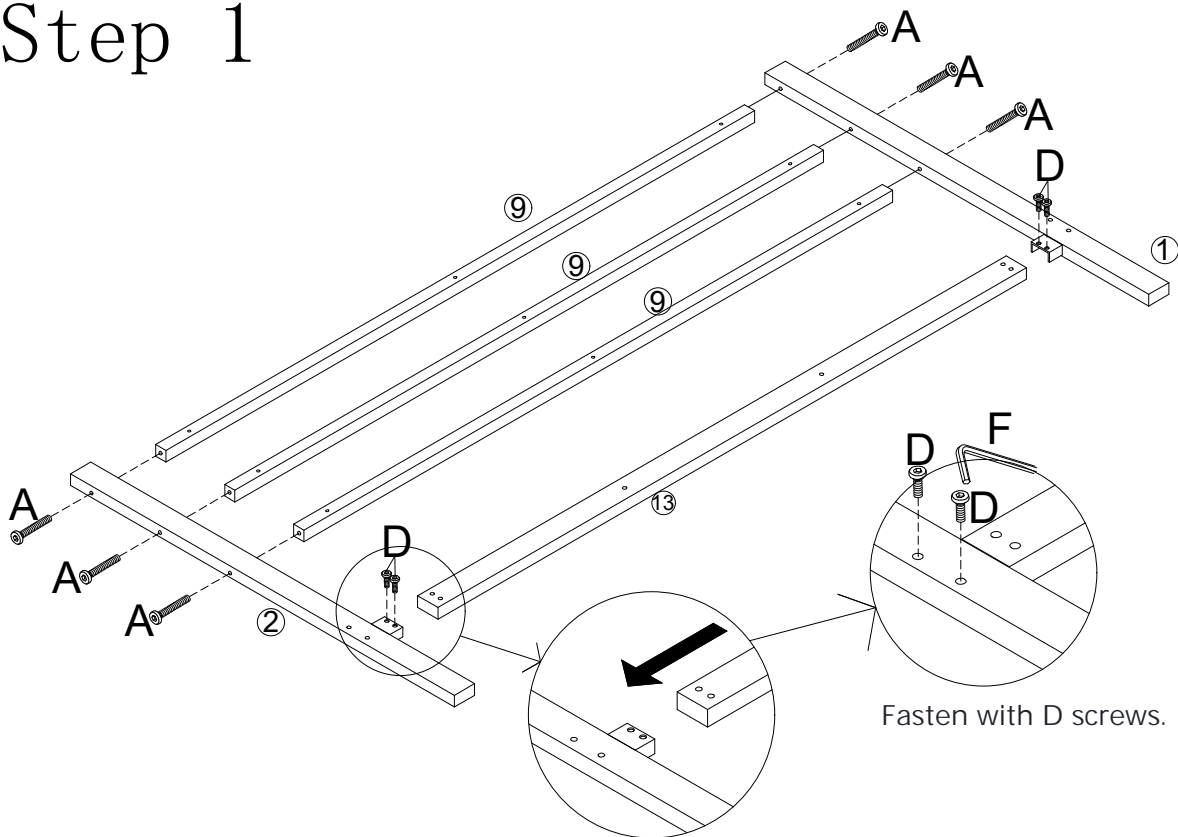

# Step 1



A	X6PCS	D	X4PCS	F	X1PC
					
M8X70MM		M8X15MM			

Fix together

# Step 2

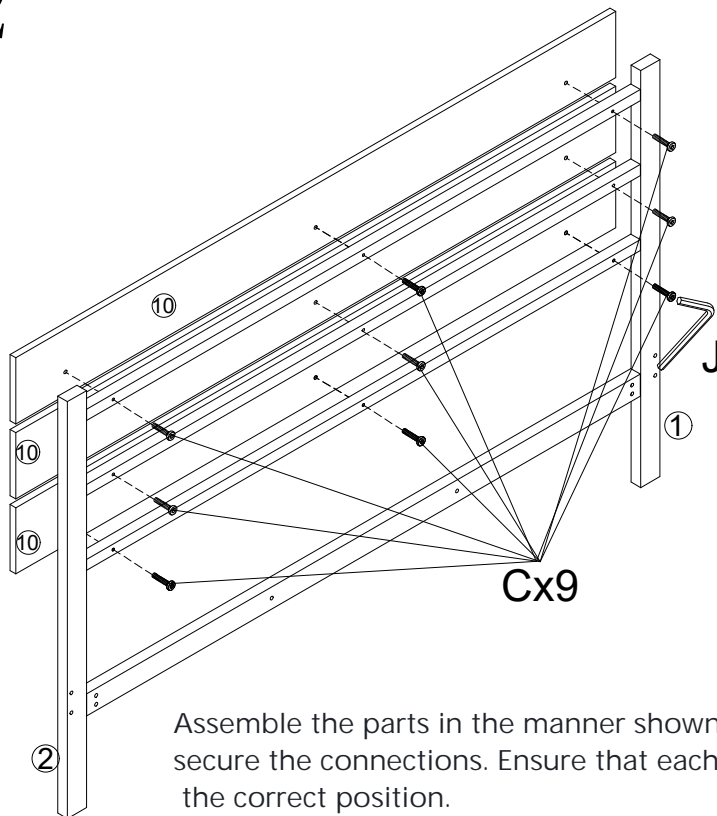

Assemble the parts in the manner shown. Use C screws to secure the connections. Ensure that each part is installed in the correct position.

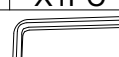
C	X9PCS	J	X1PC
			
M6X35MM			

# Step 3

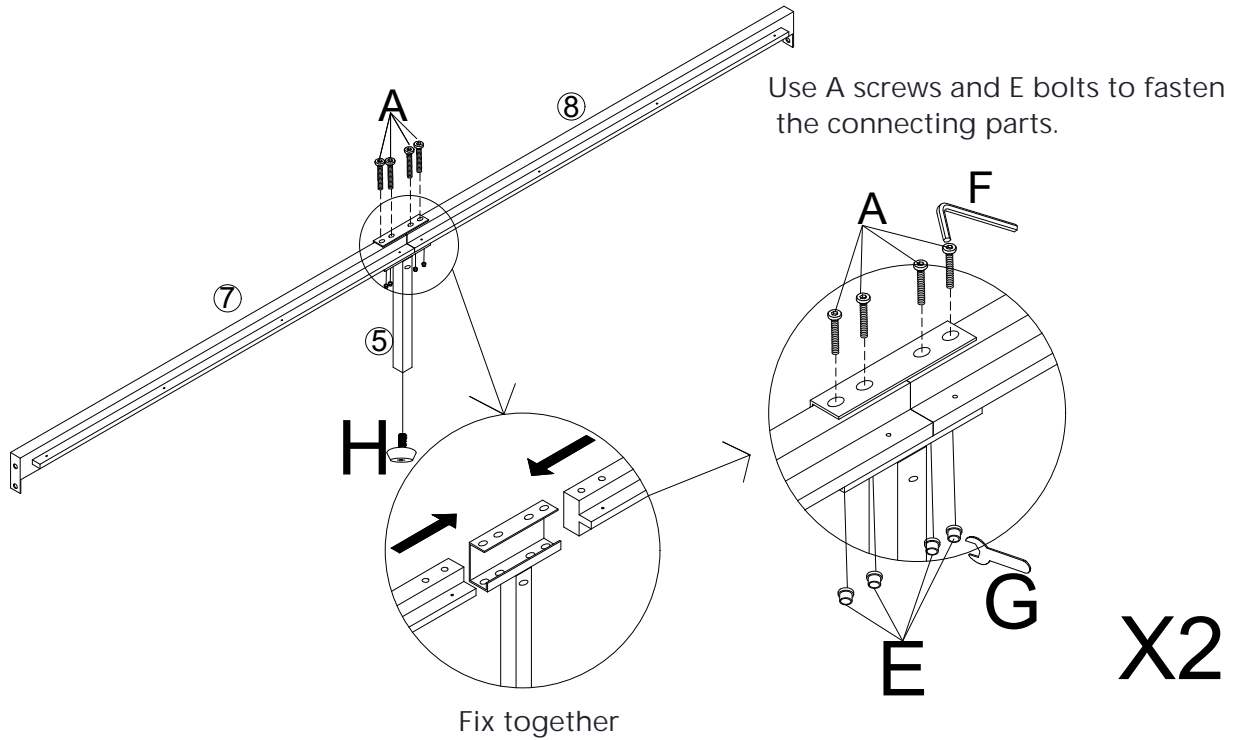

A	X8PCS	E	X8PCS	F	X1PC	G	X1PC	H	X2PCS
M8X70MM		M8							

# Step 4

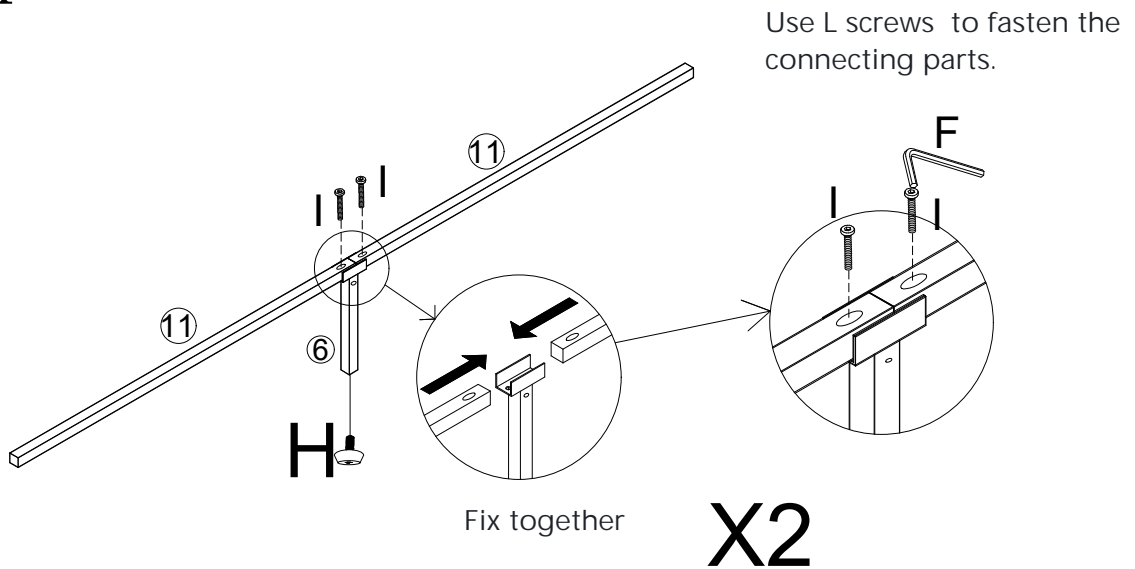

I	X4PCS	F	X1PC	H	X2PC
M8X35MM					

# Step 5

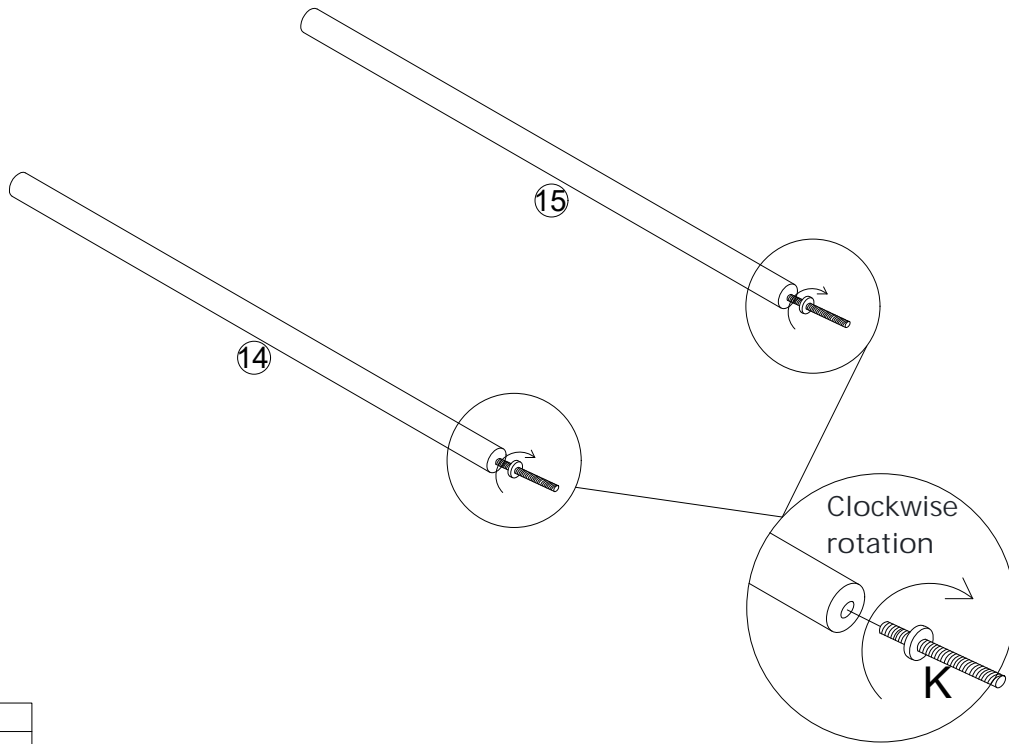

K	X2PCS
	
M6X50MM	

# Step 6

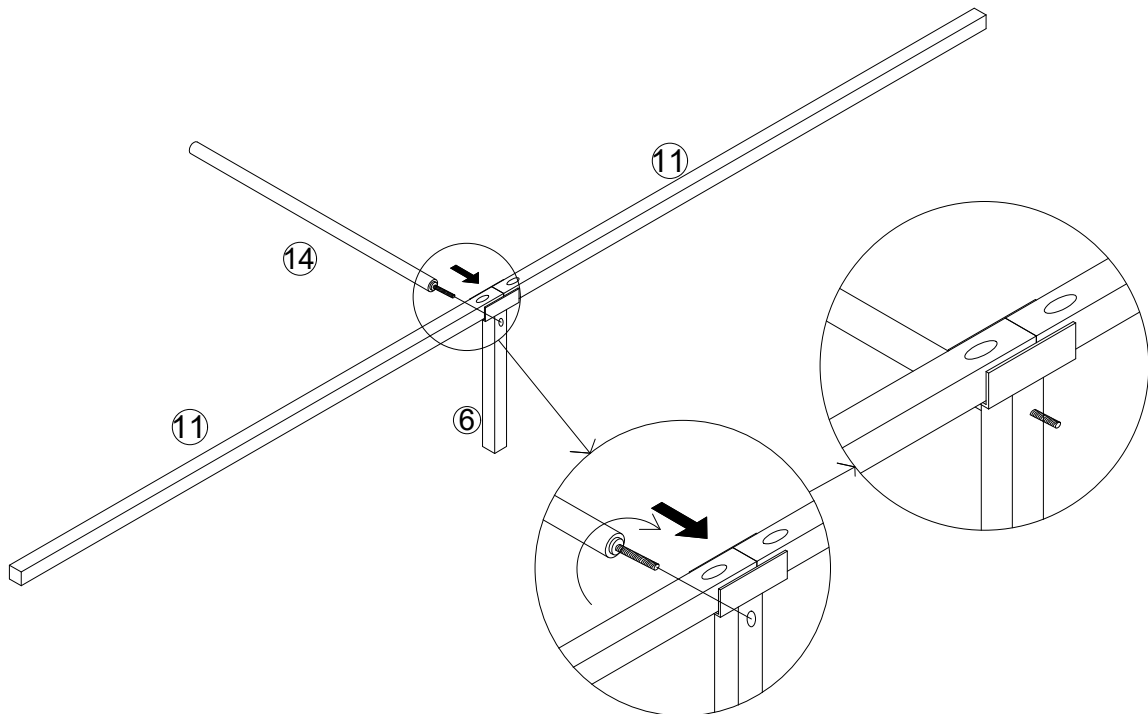

Place the component through the pre-drilled holes in a clockwise direction.

# Step 7

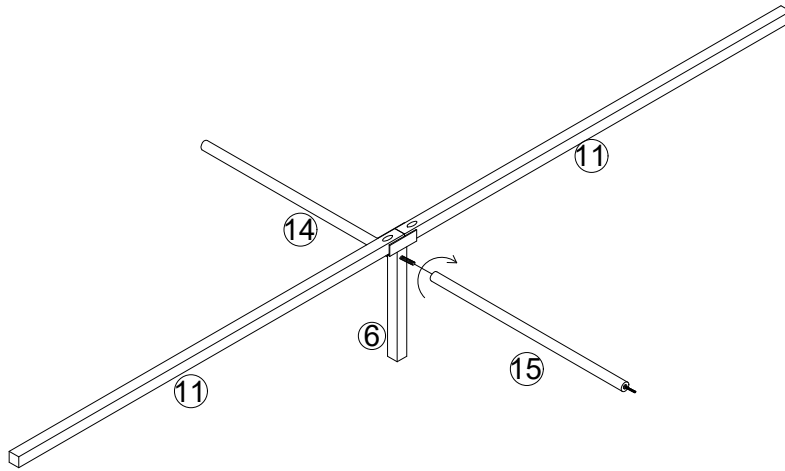

Place the componet through the pre-drilled holes in a clockwise direction.

# Step 8

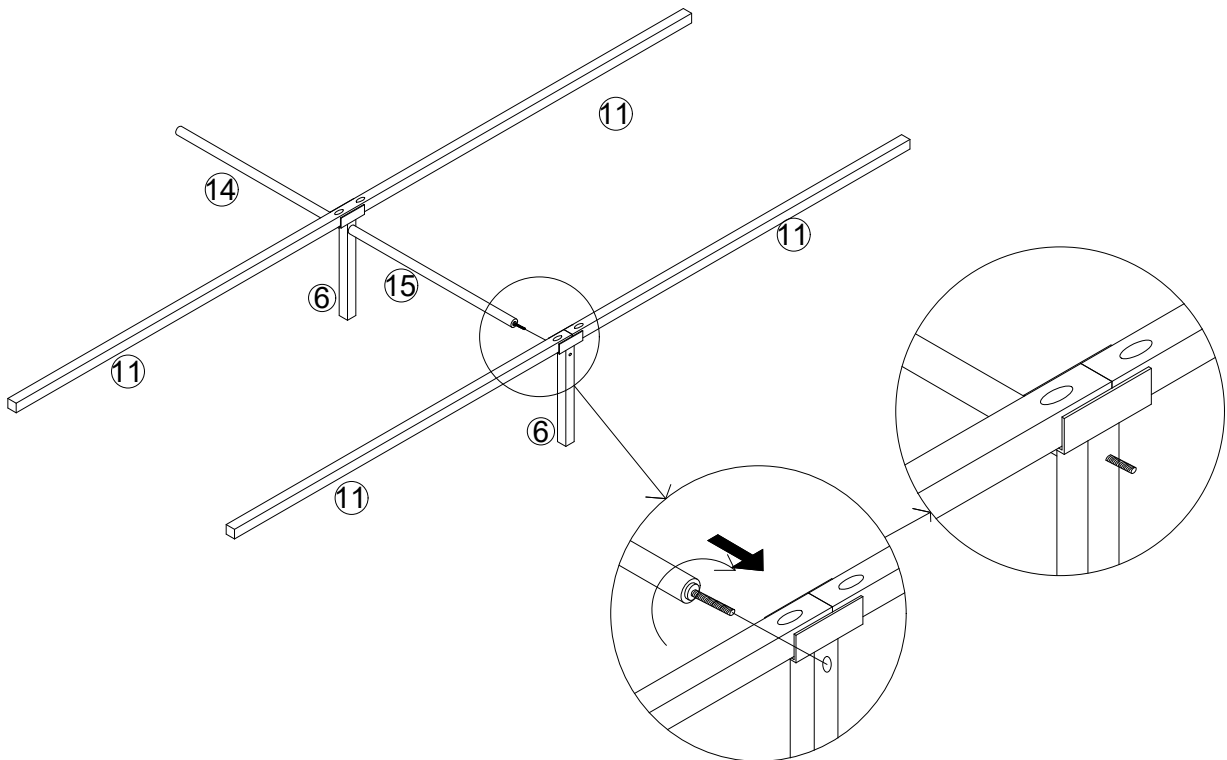

Place the componet through the pre-drilled holes in a clockwise direction.

# Step 9

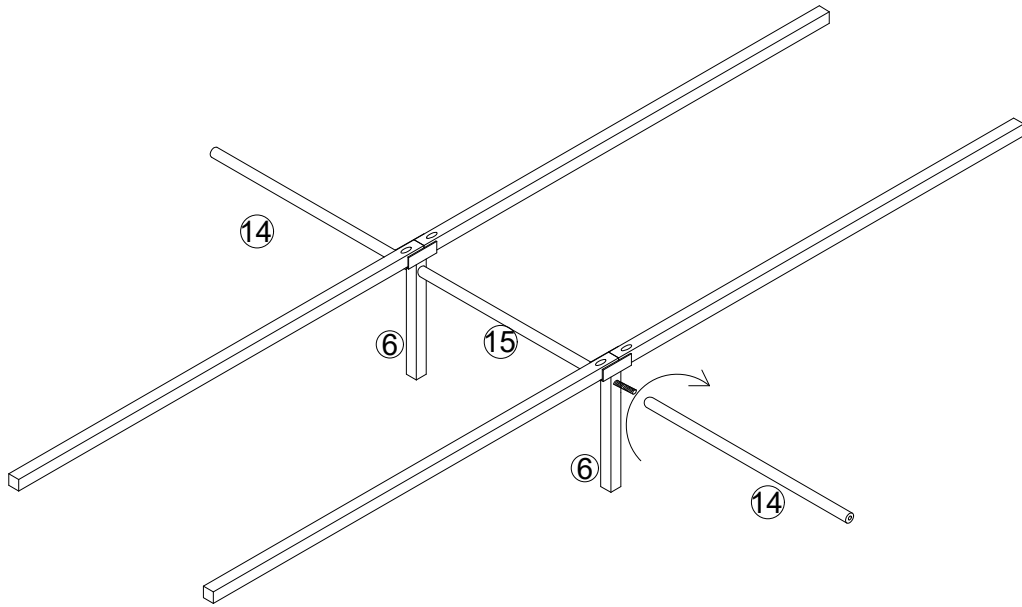

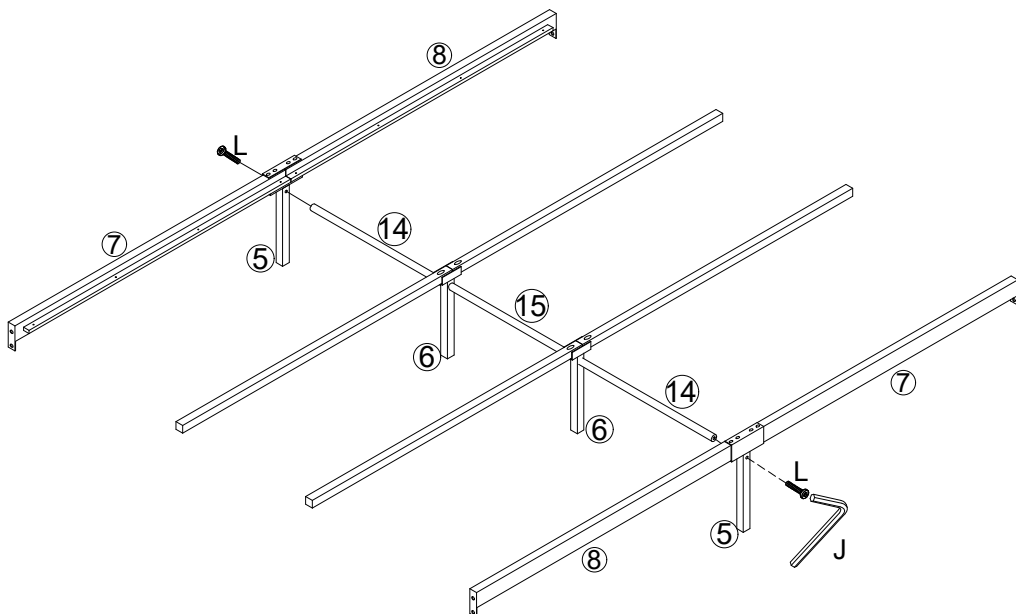

Place the component through the pre-drilled holes in a clockwise direction.

# Step 10



Use screw L secure with the connection in each side.

L	X2PCS	J	X1PC
			
M6X40MM			

# Step 11

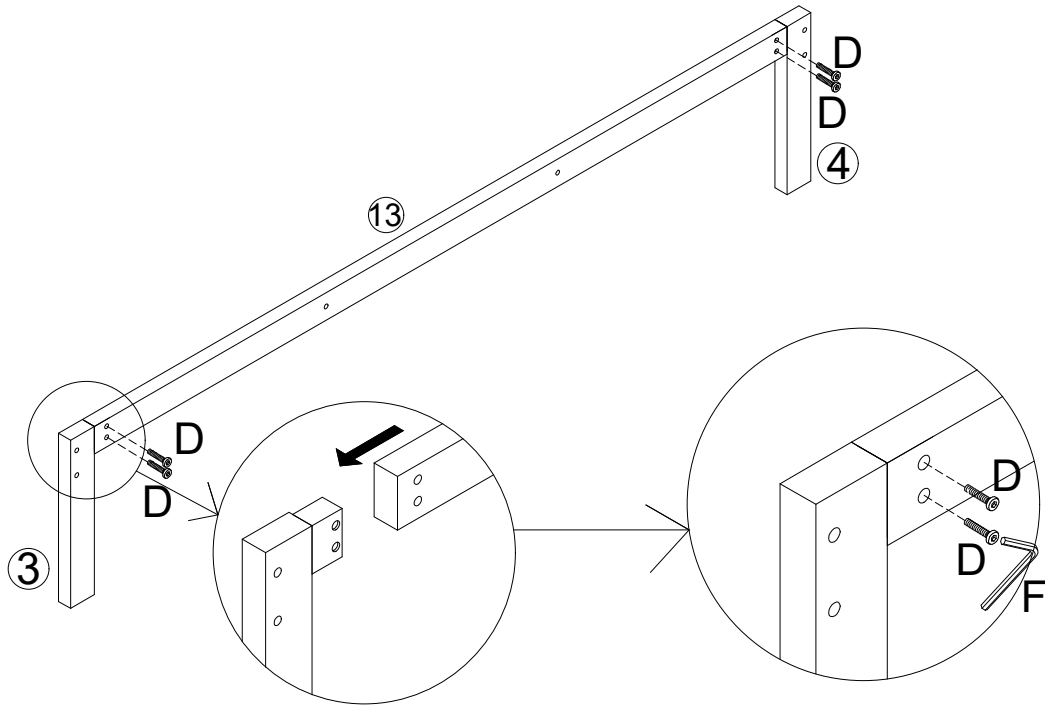

Fix together

Use D screws to fasten the connecting parts.

D	X4PCS	F	X1PC
M8X15MM			

# Step 12

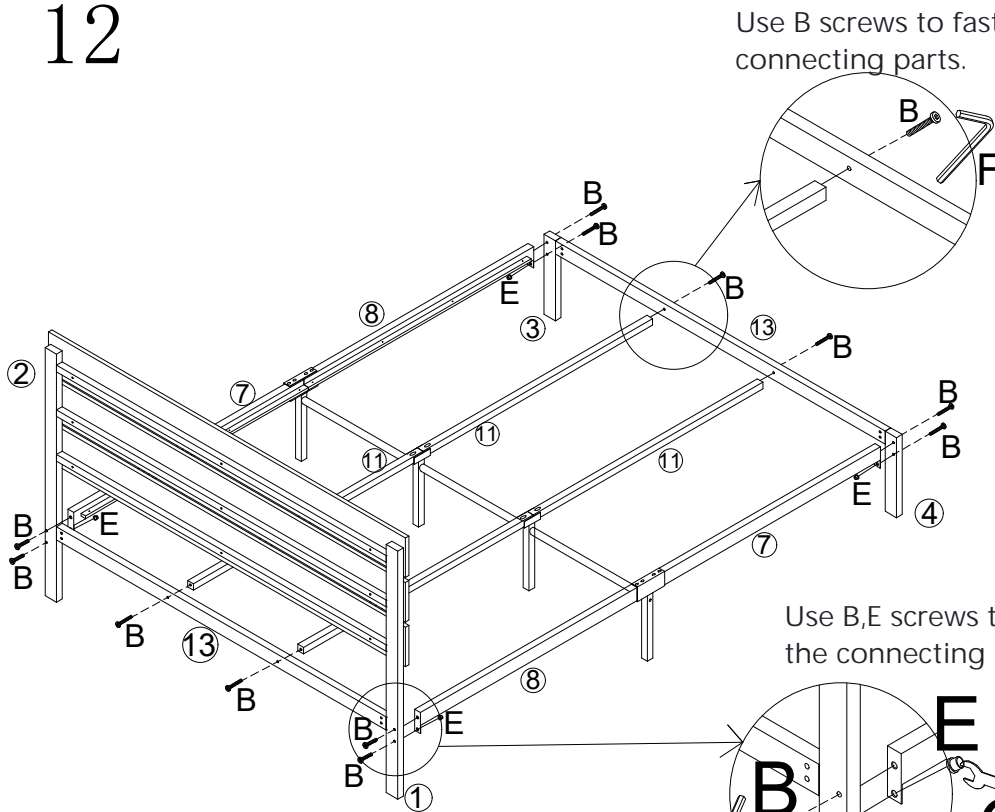

Use B screws to fasten the connecting parts.

Use B,E screws to fasten the connecting parts.

B	X12PCS	E	X4PC	F	X1PC	G	X1PC
M8X45MM		M8					

# Step 13

Place the slat in the main structure

