

Capri 1800GBLK/LO/DO

Assembly Instruction Manual

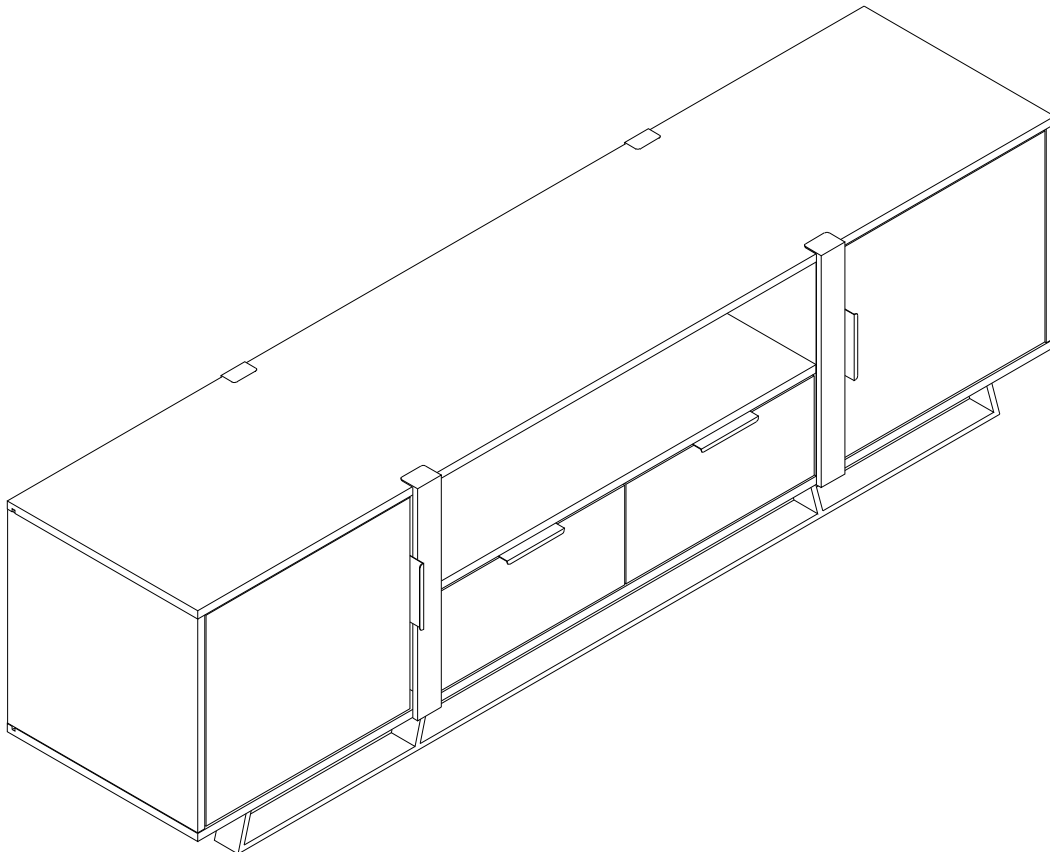

-
- Please follow these assembly instructions as it will save you time, make assembly easier and prevent possible damage to your new unit.
 - Correct assembly is your responsibility
 - We strongly recommend that the unit is assembled on a soft surface such as carpet or blanket.
-

 **Criterion**

Capri 1800GBLK/LO/DO

UNPACK & IDENTIFY PARTS

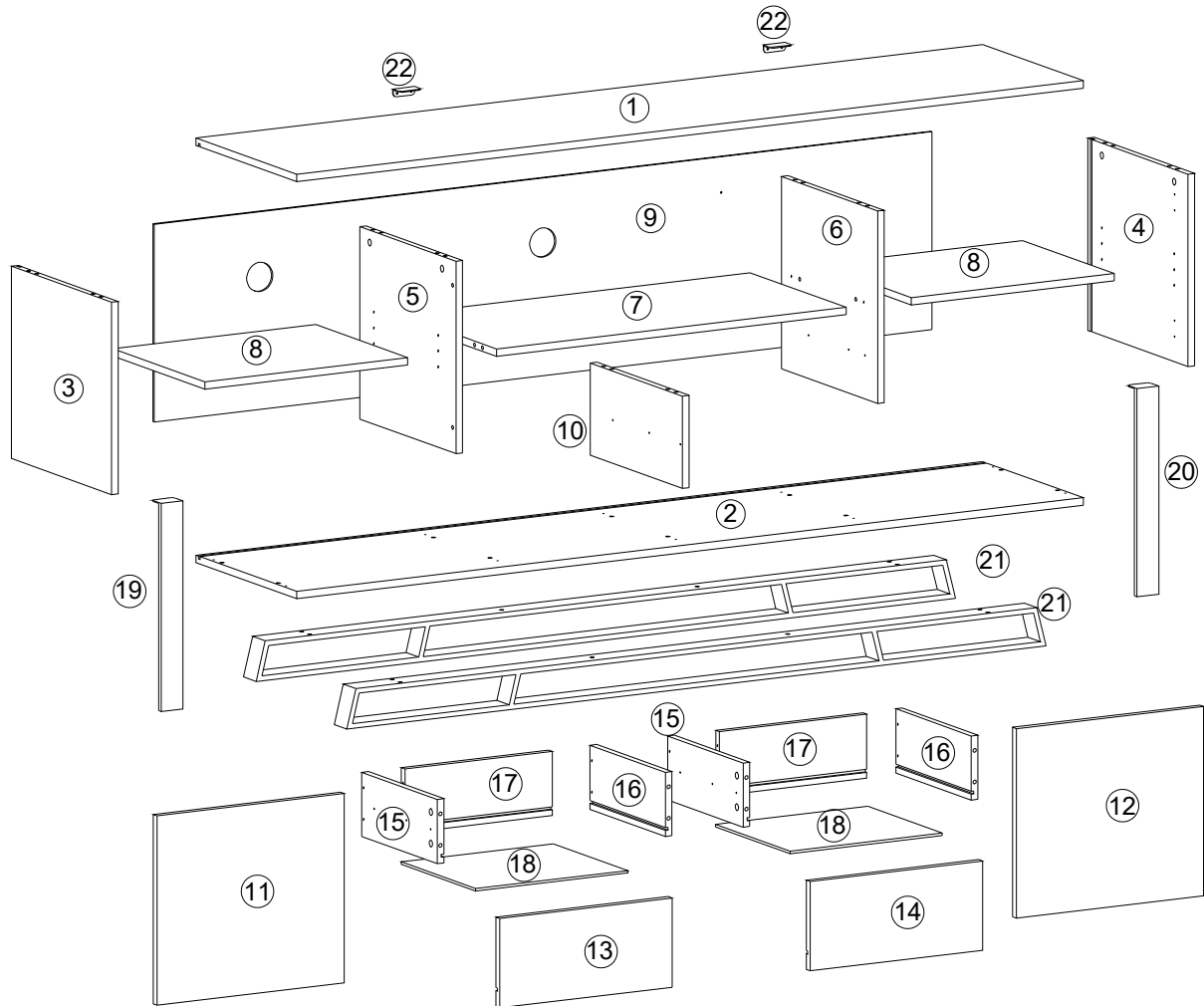













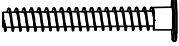

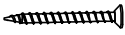

Customer Service

FOR MISSING OR FAULTY PARTS: PLEASE RECHECK YOUR PACKAGING TO ENSURE THAT PARTS ARE MISSING, THEN CONTACT THE STORE YOU PURCHASED THE ITEM FROM, PROVIDING THE DETAIL IN 1 - 5 BELOW

1. MODEL NUMBER OF THE UNIT PURCHASED
2. COPY OF YOUR PURCHASE SLIP / INVOICE
3. DESCRIPTION OF THE MISSING PART
4. PART NUMBER OF THE MISSING PART
5. QUANTITY OF THE PARTS MISSING

IMPORTANT: MISSING / DAMAGED PARTS WILL NOT BE REPLACED UNLESS THE INFORMATION REQUESTED IS SUPPLIED IN FULL.

Hardware List

A		Ø8*30		24PCS
B		Ø15*11		22PCS
C		Ø6*35		22PCS
D		Ø6*48		10PCS
E		M6*20		12PCS
F		M6*12		4PCS
G		Ø4*30		12PCS
H		Ø3.5*14		24PCS
I		Ø3.5*12		36PCS
J		L=300mm		2PCS
K				4PCS
L				4PCS
M		45*100*1.5		6PCS
N		30*17*15mm		8PCS
O		Ø10*2		2PCS
P		15*15*12		4PCS
Q		Ø3*18		4PCS
R		M4		1PCS

**Slides Must Be Separated Before Assembly.
After Separated, Set Aside Until Needed for Assembly.**

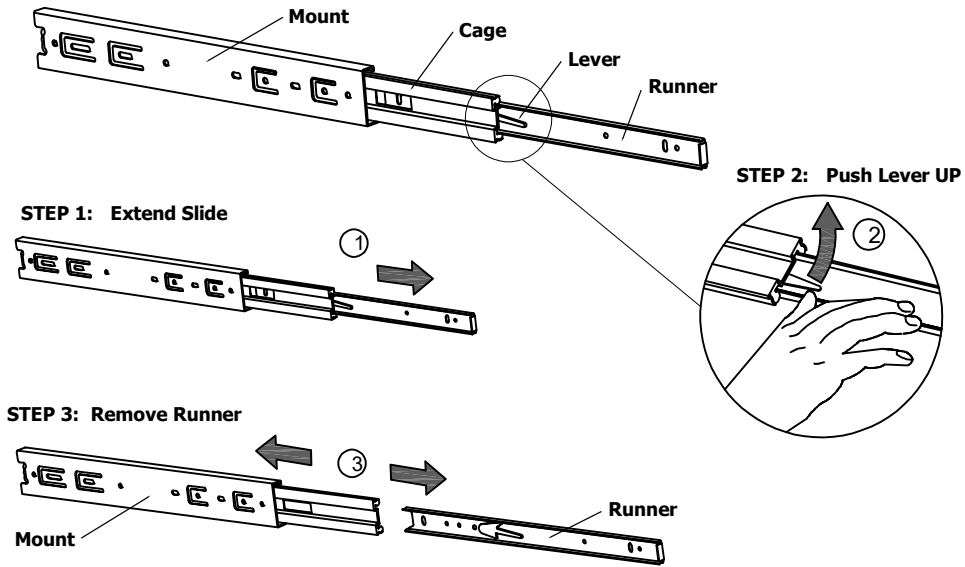

Step 1

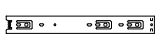
	I x 6		J x 2
---	-------	---	-------

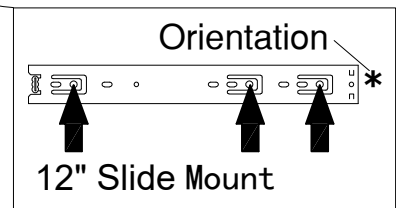
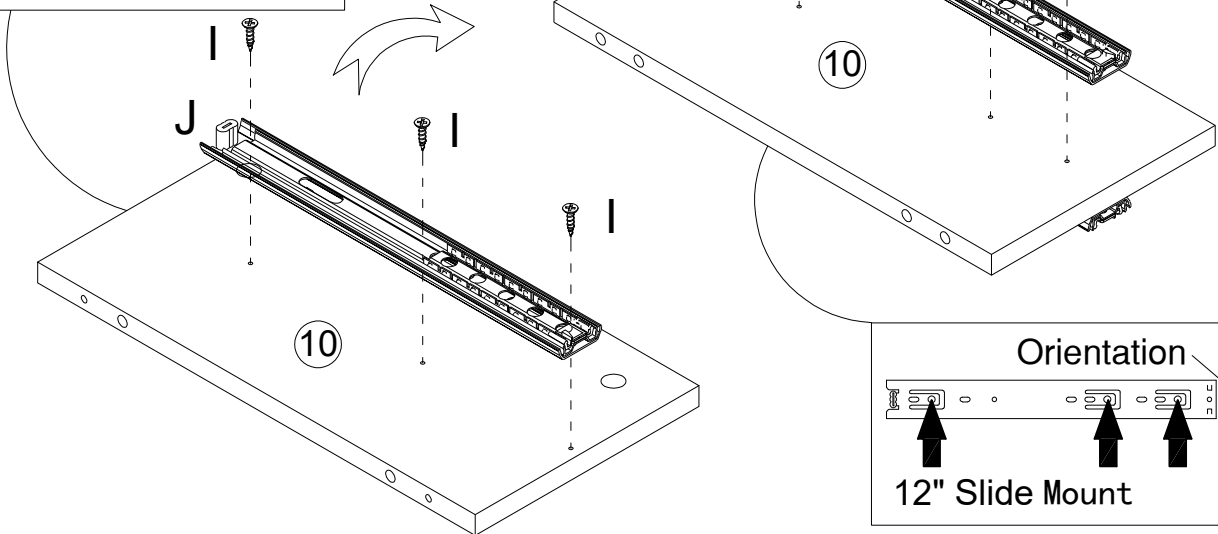
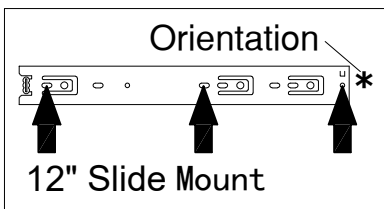

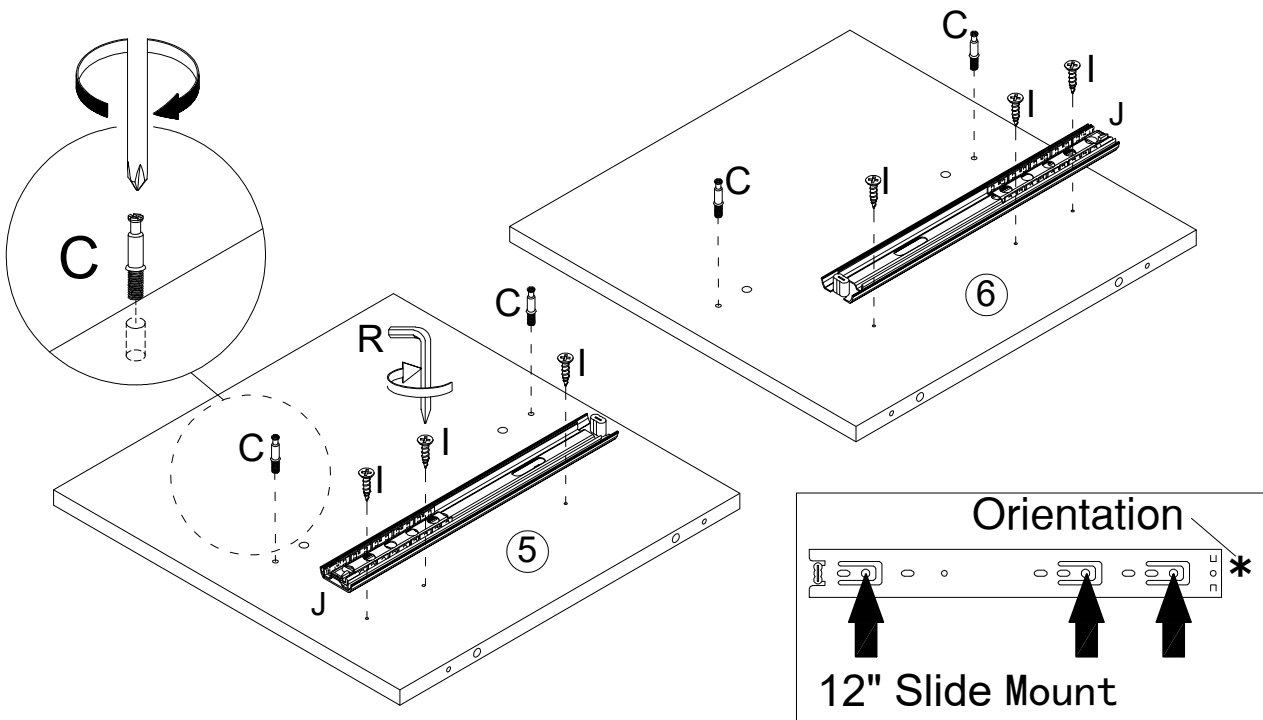
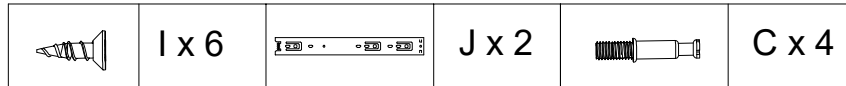

Step 2

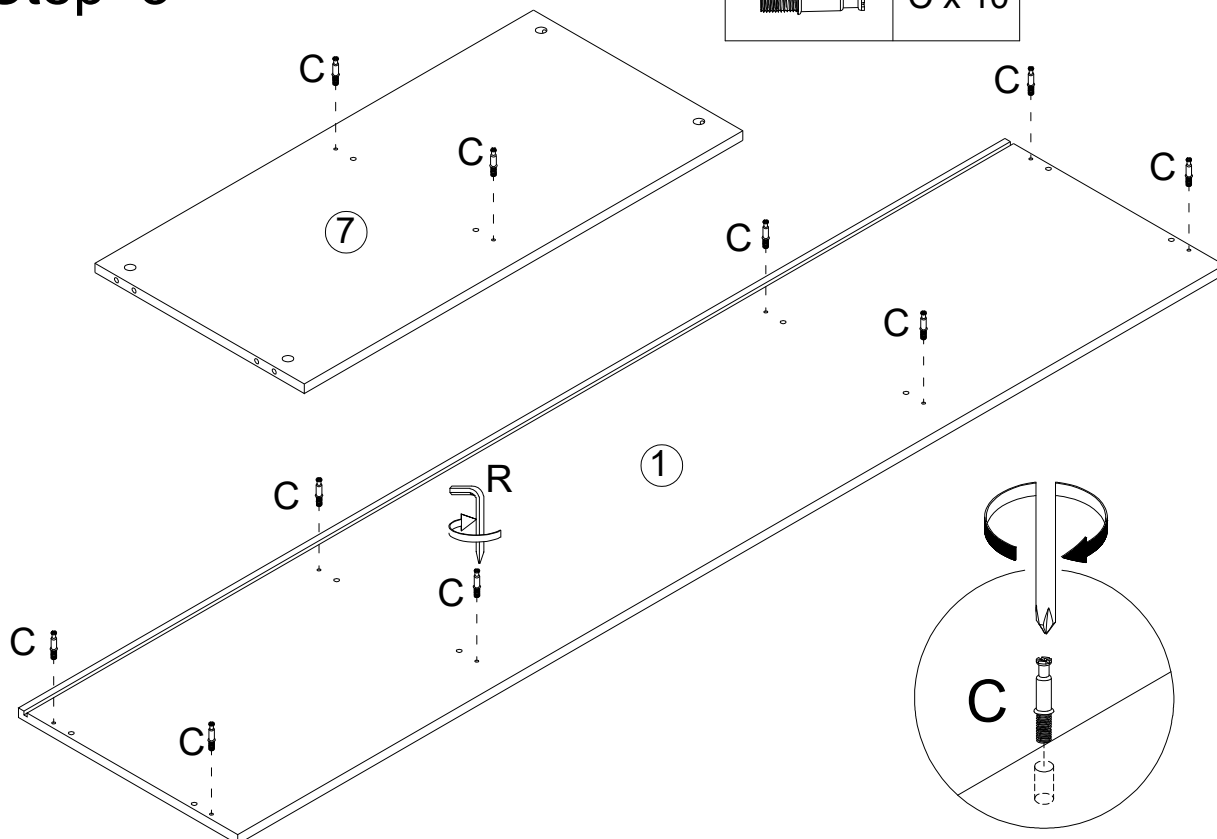
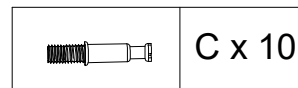

Step 3



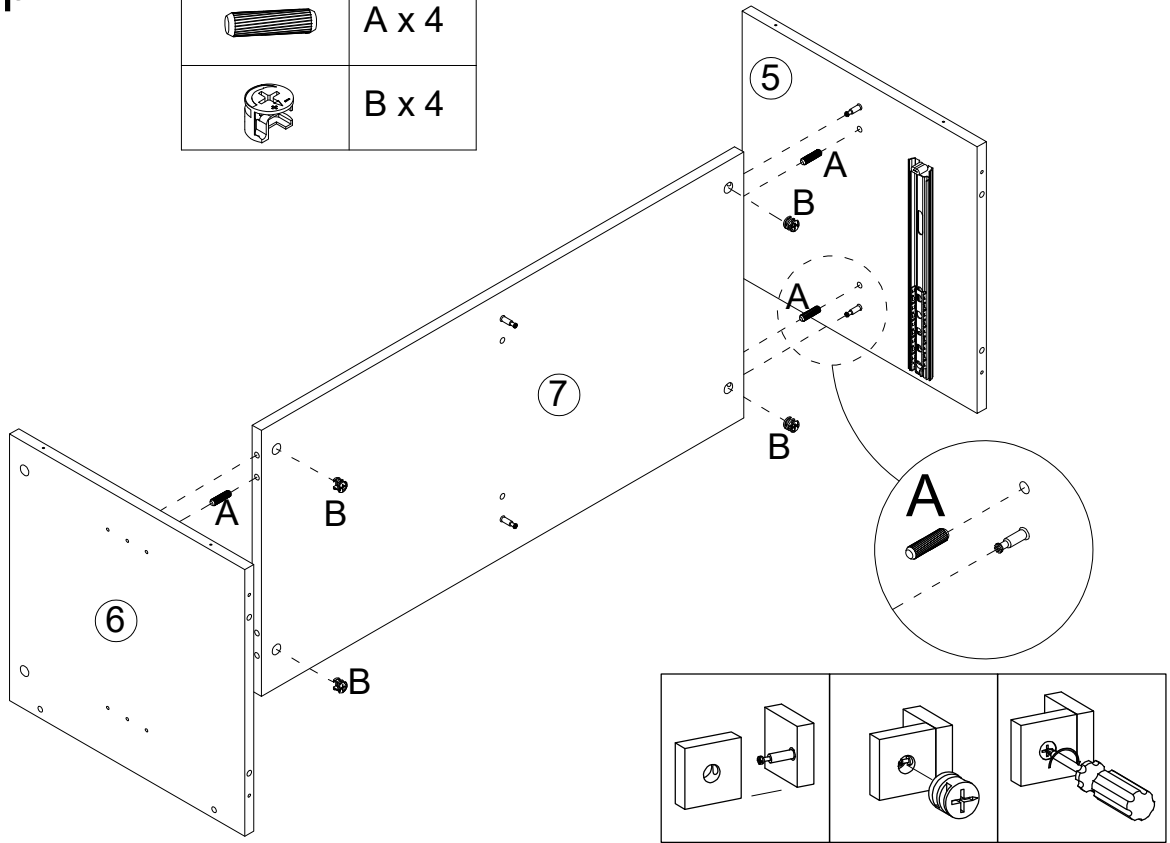

Step 4

	A x 4
	B x 4



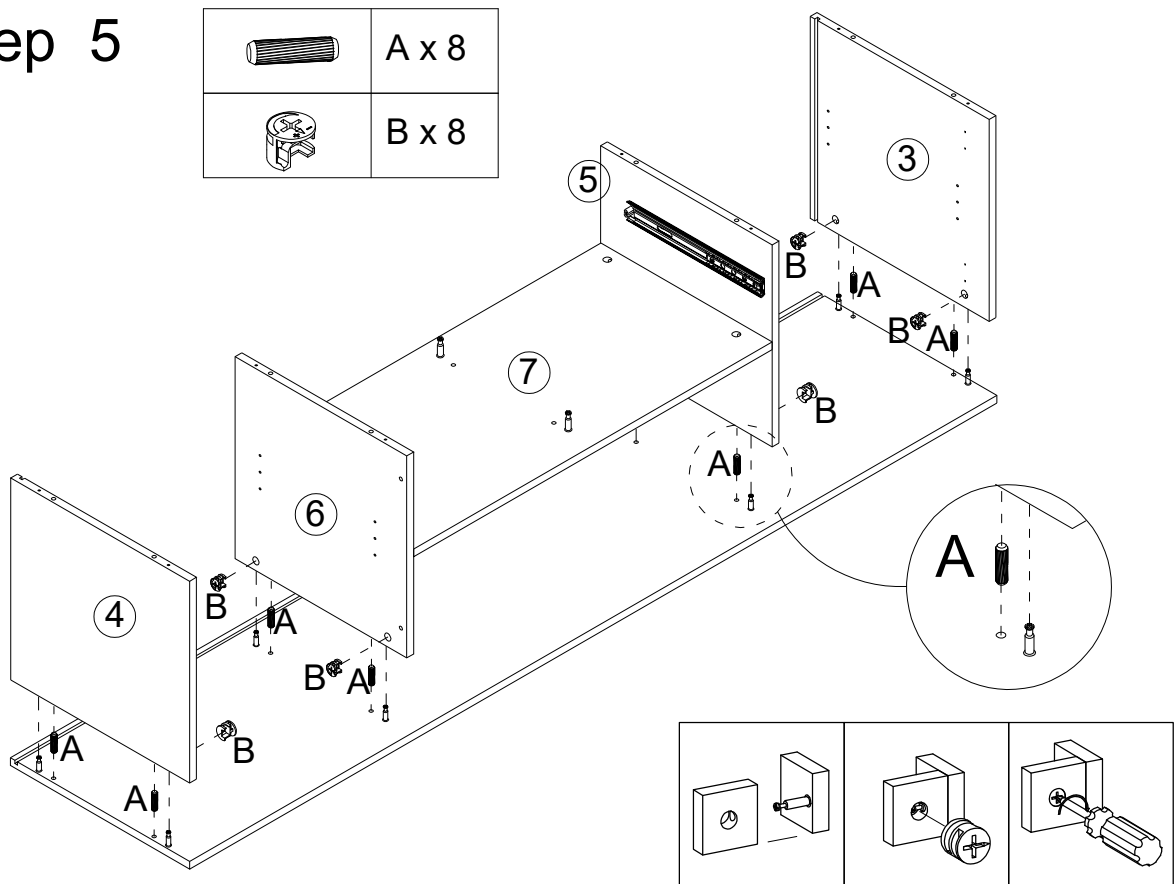

Step 5

	A x 8
	B x 8



Step 6

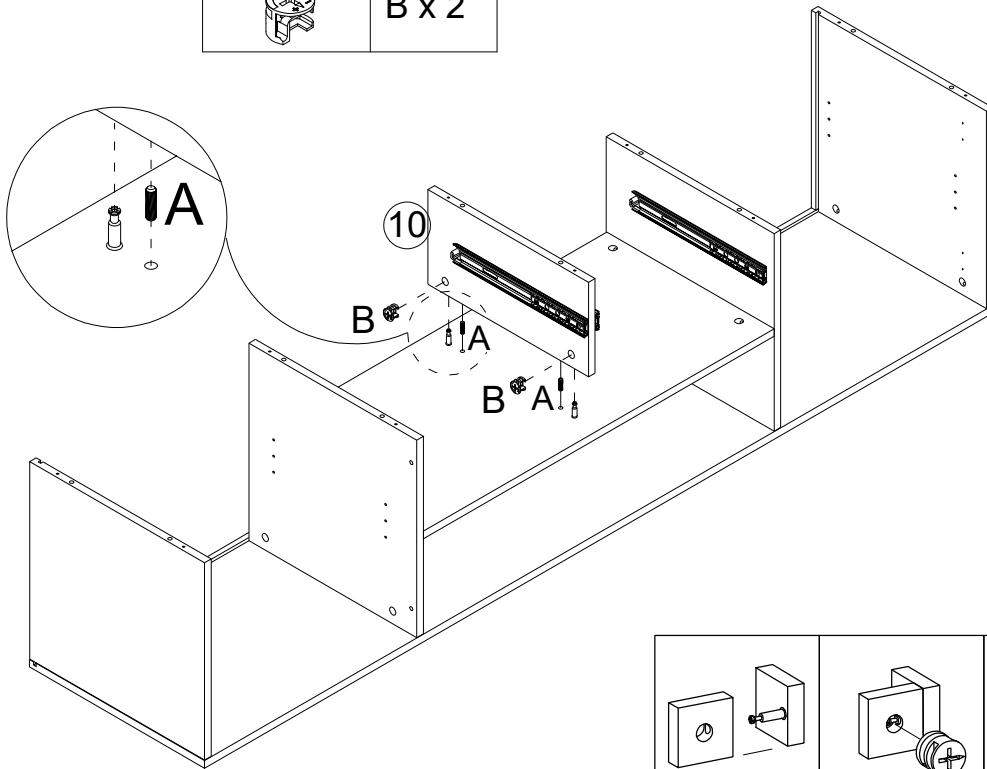

	A x 2
	B x 2

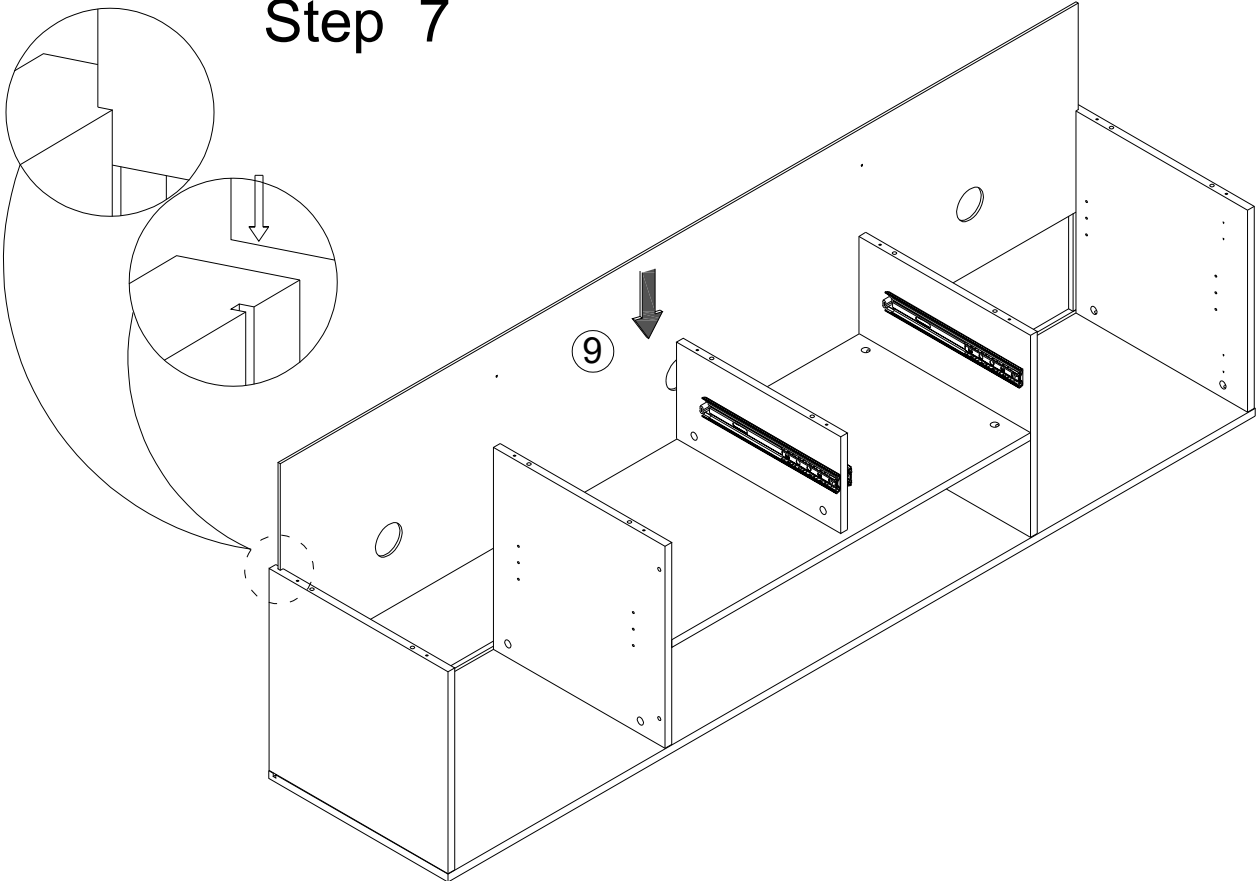

Step 7



Step 8

	A x 10
	D x 10

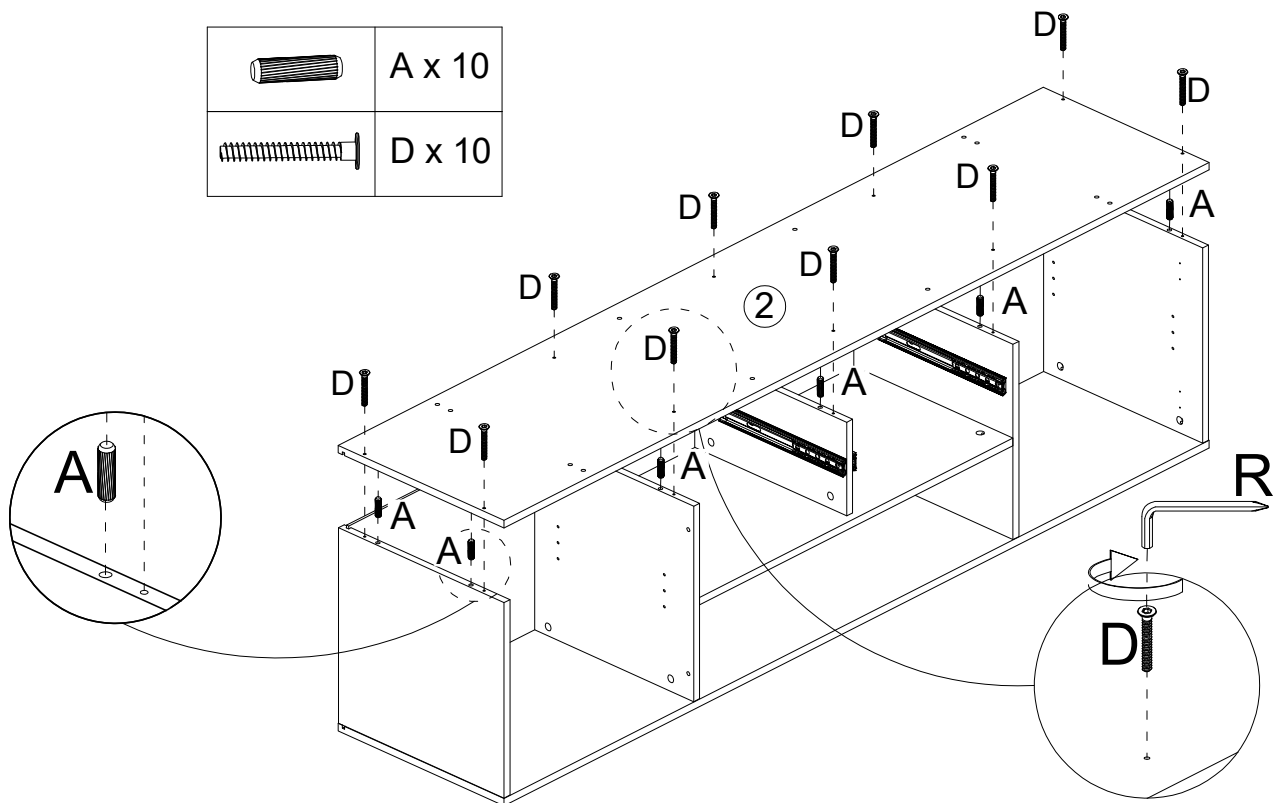

Step 9

	E x 12
---	--------

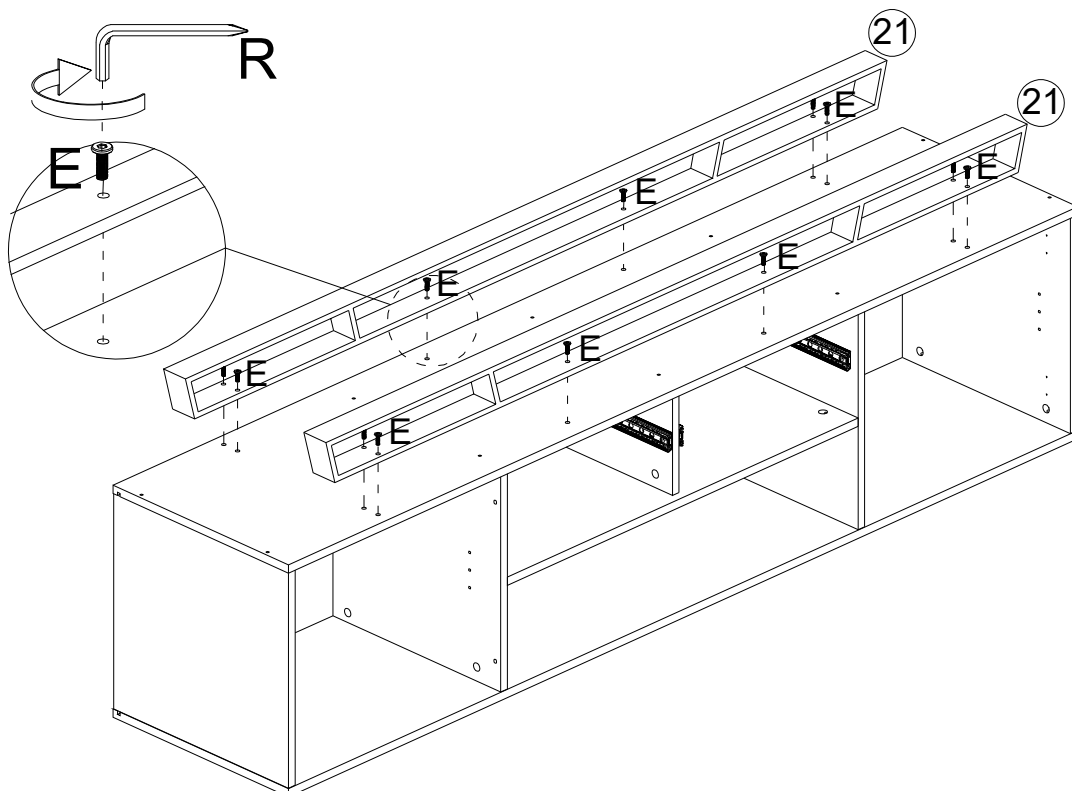

Step 12

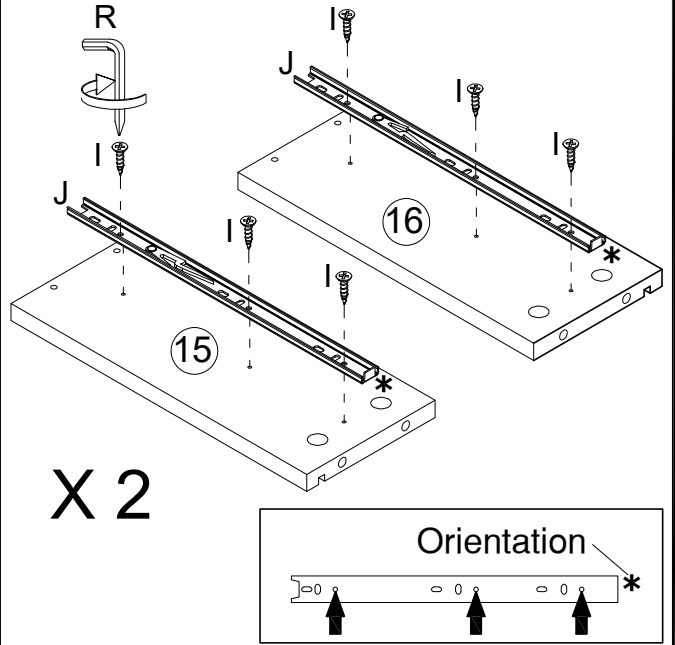
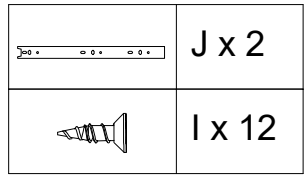
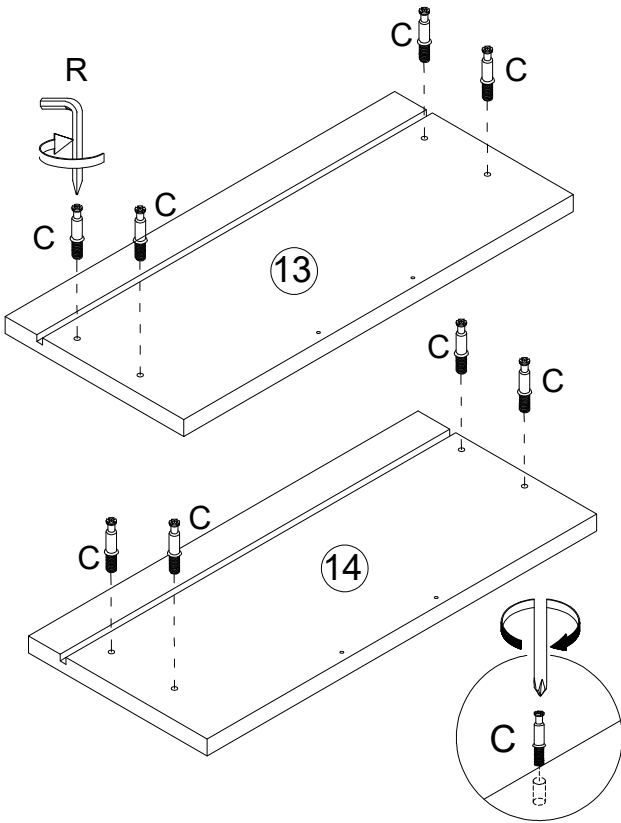
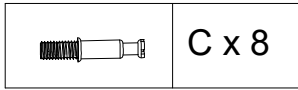

X 2

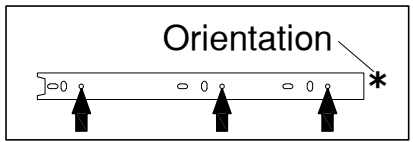

Step 13

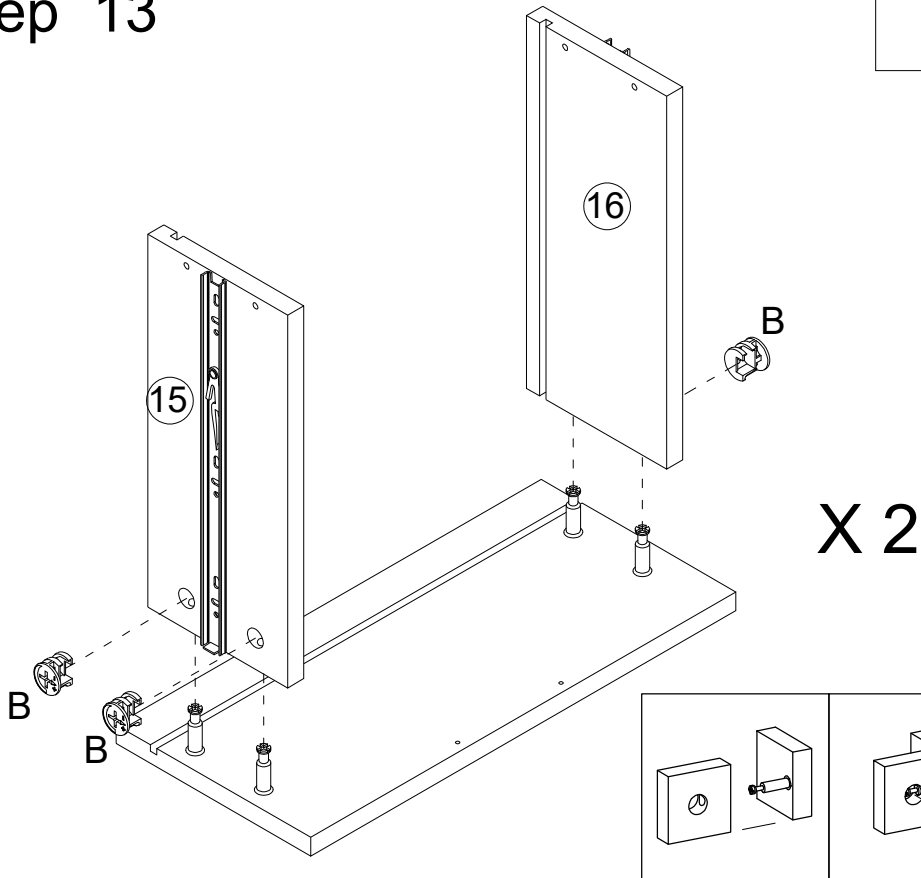

X 2

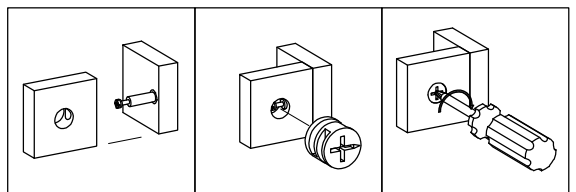

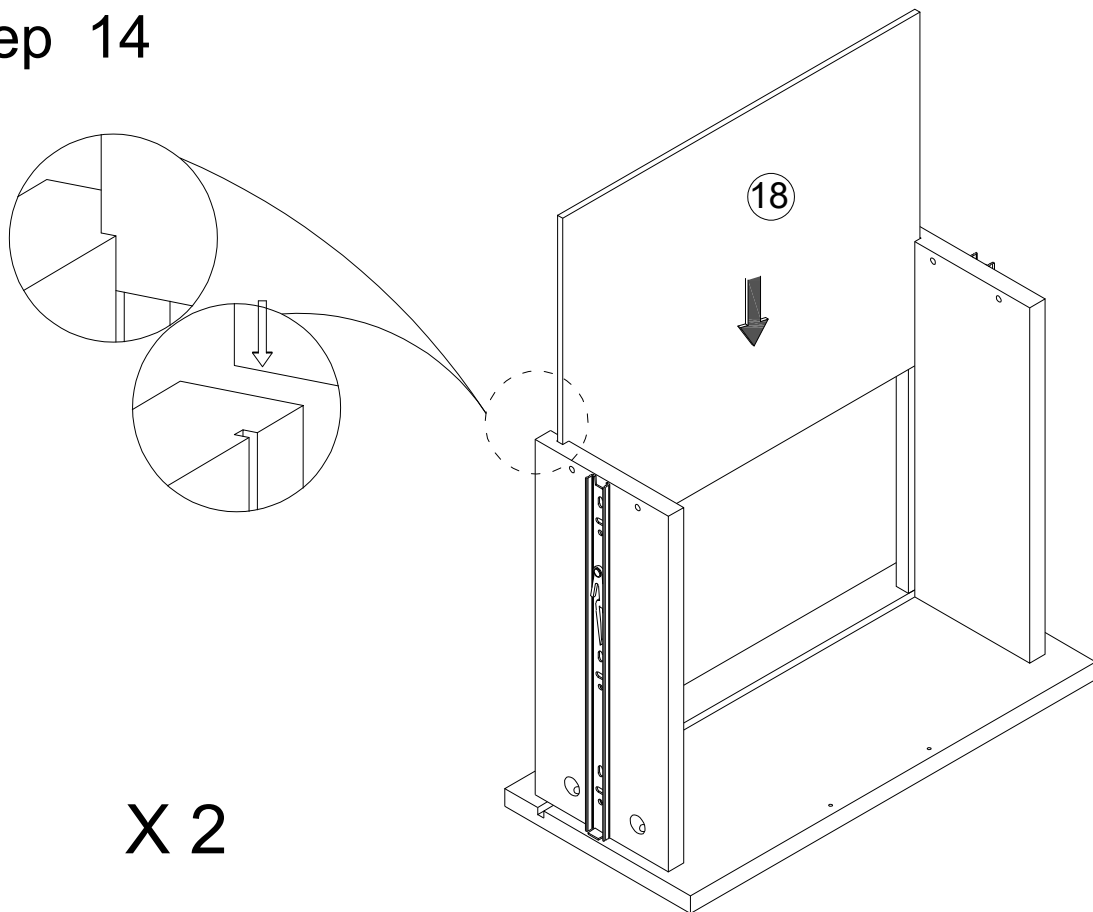

Step 14

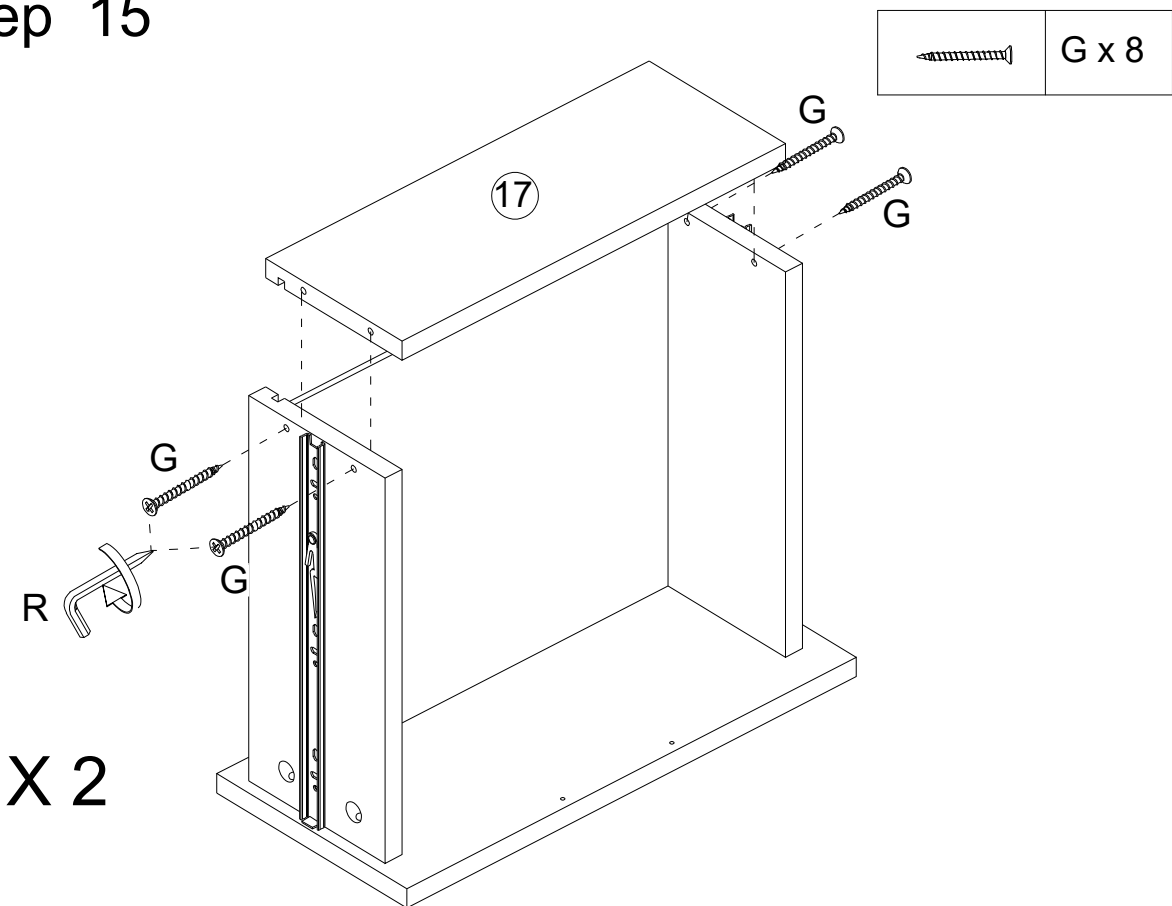

Step 15



Step 16

	K x 2		I x 4
---	-------	---	-------

X 2

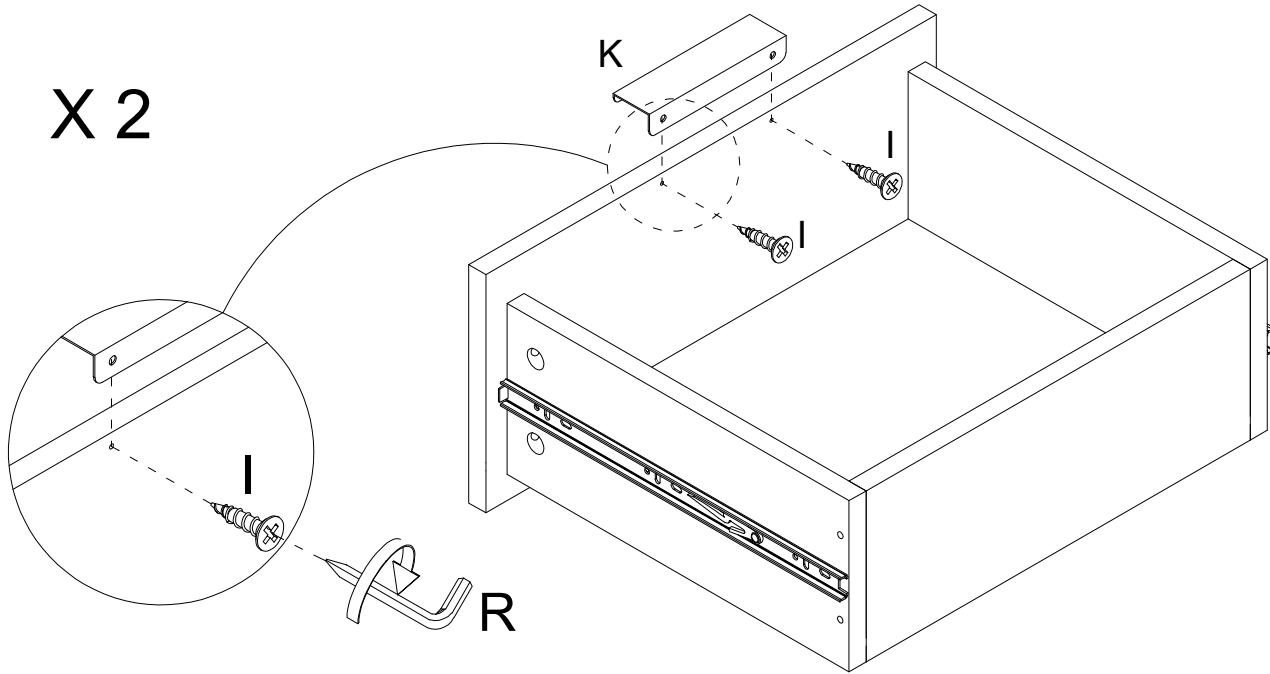

Step 17

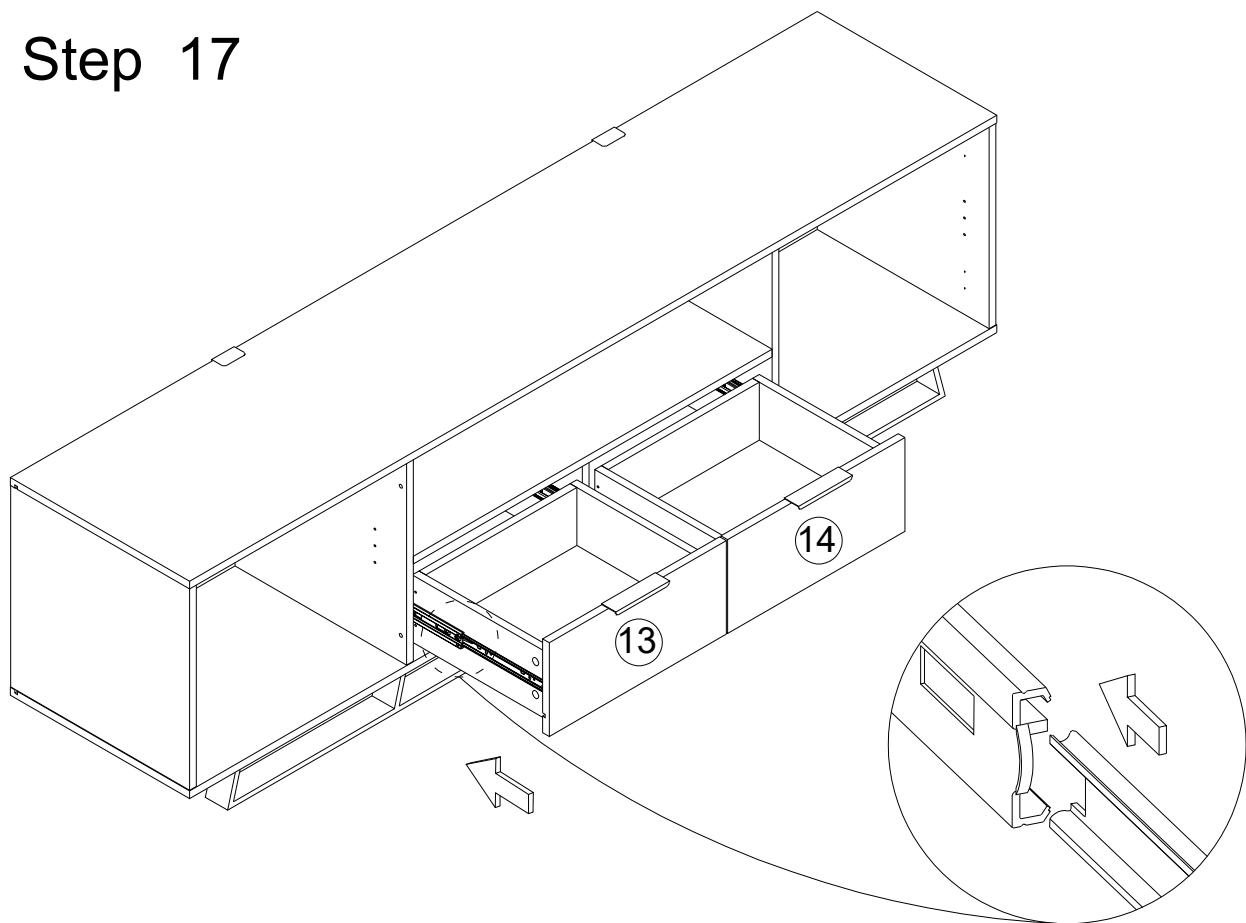

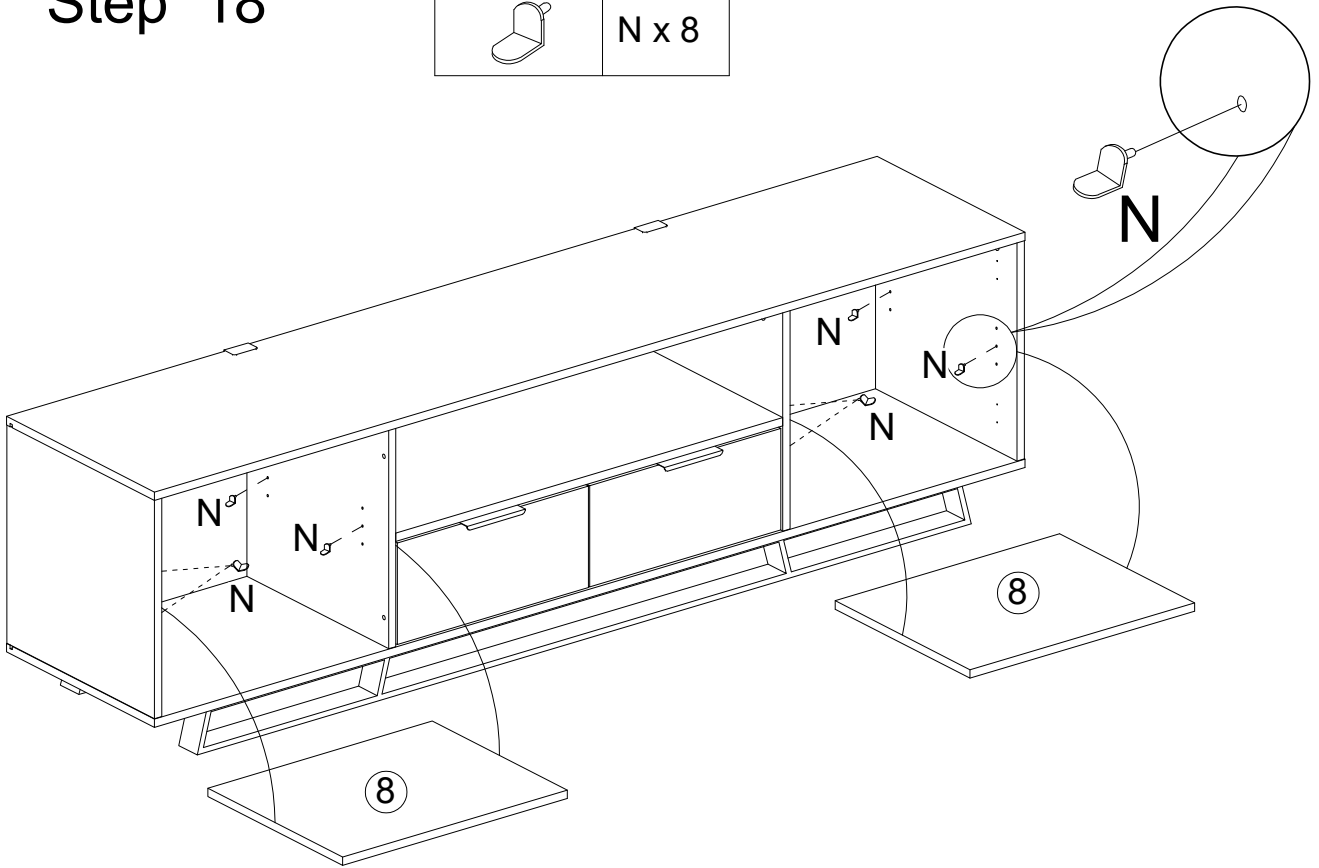
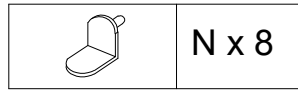

Step 18

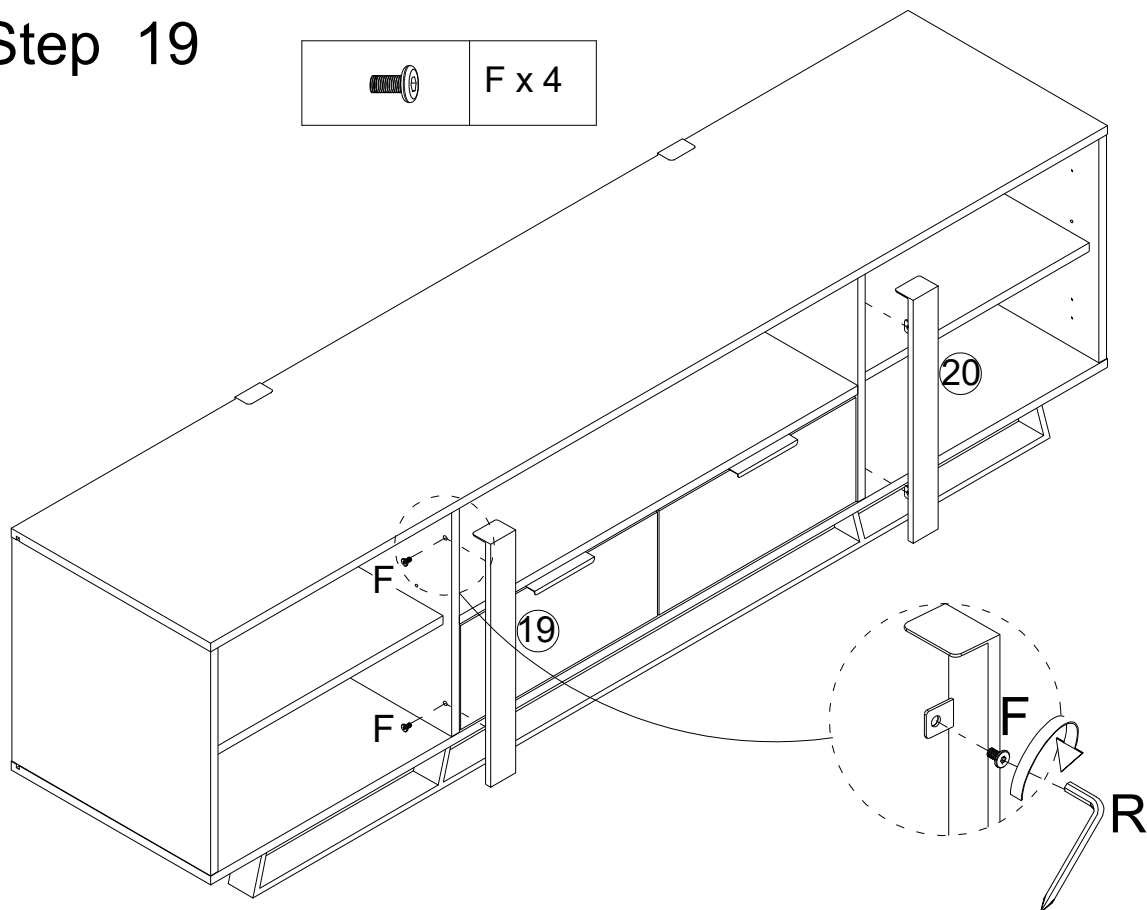
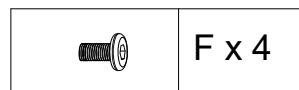

Step 19

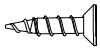
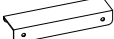

Step 20

	L x 4		H x 8
	K x 2		
	I x 4		

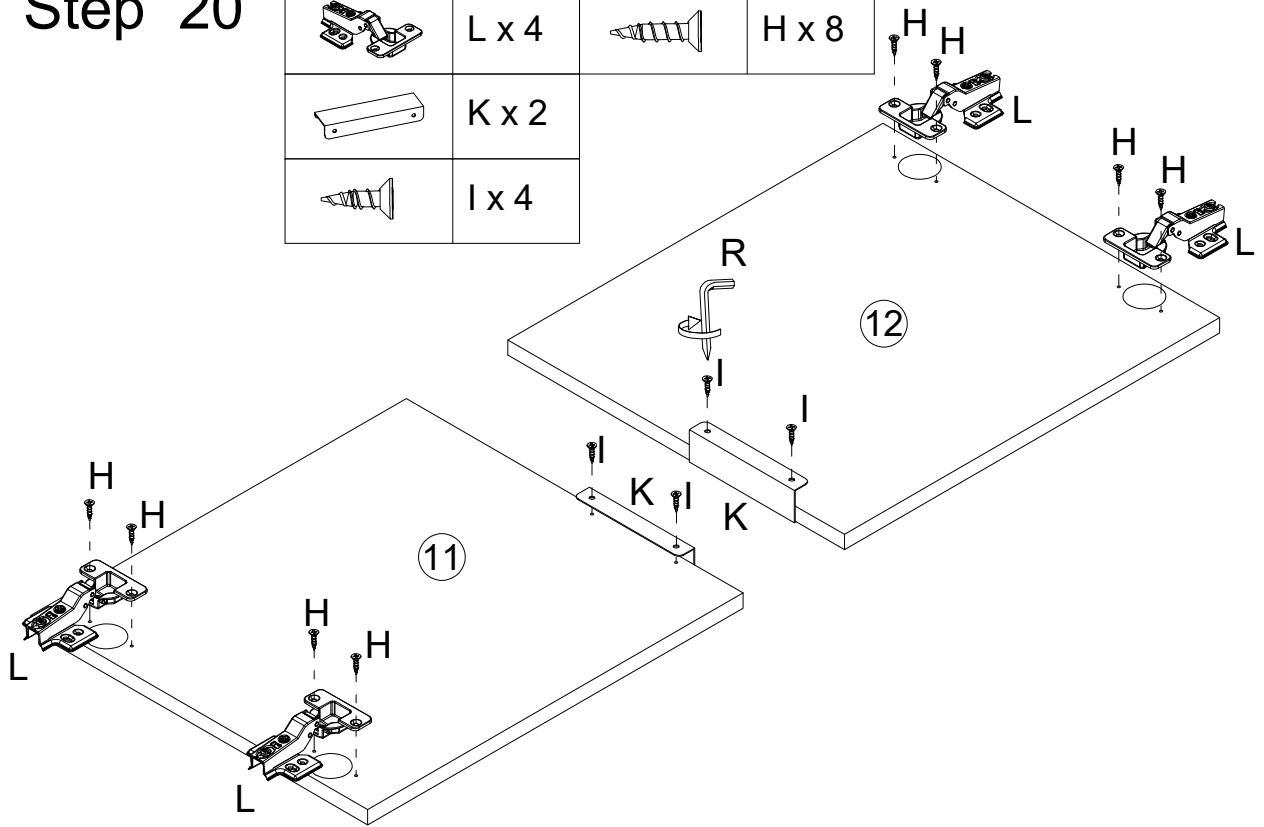

Step 21

	H x 16
---	--------

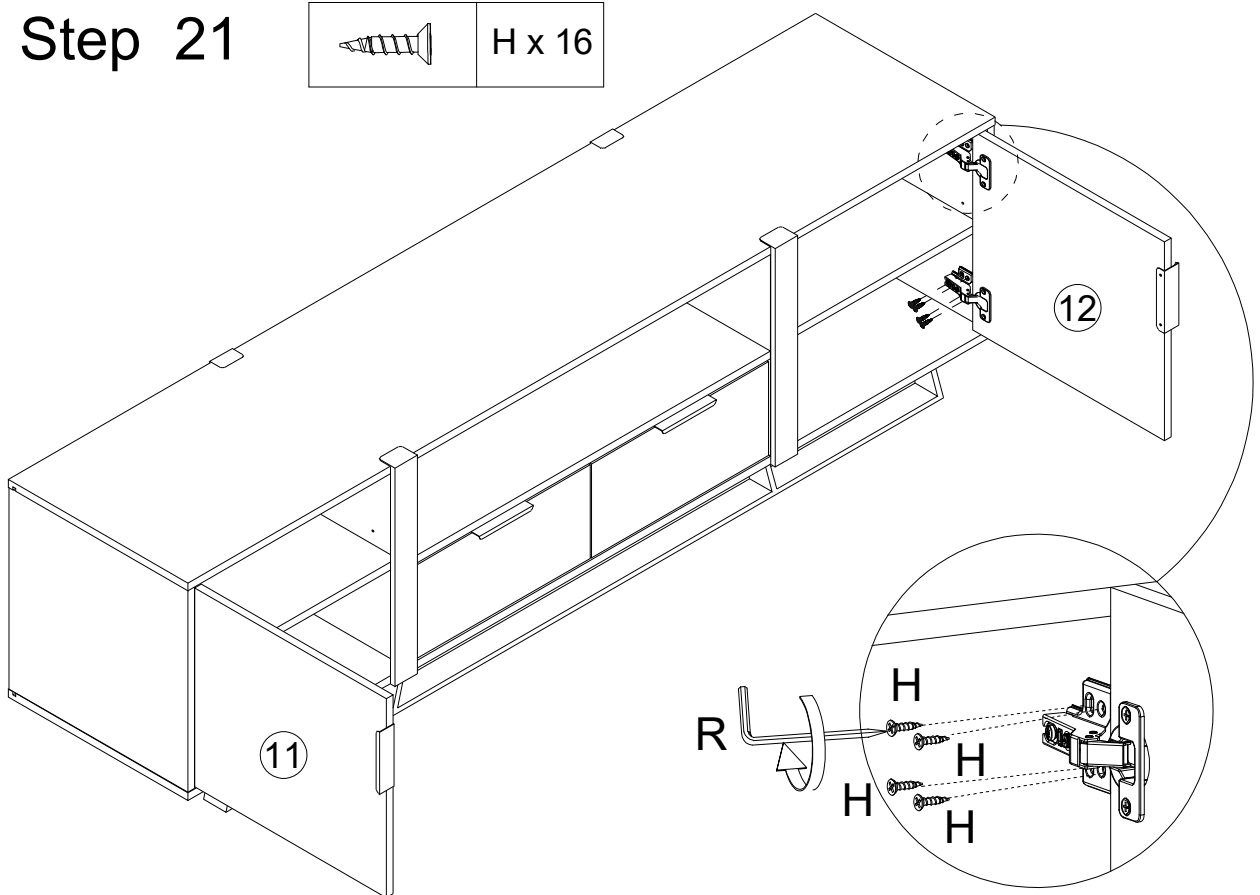

Step 22

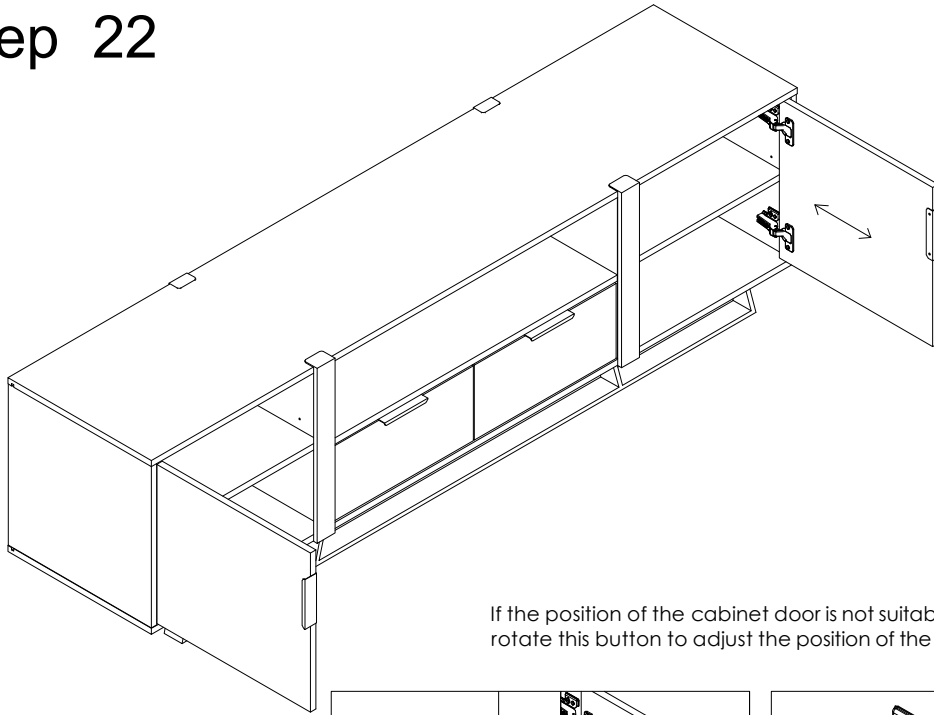

If the position of the cabinet door is not suitable, you can rotate this button to adjust the position of the cabinet door.

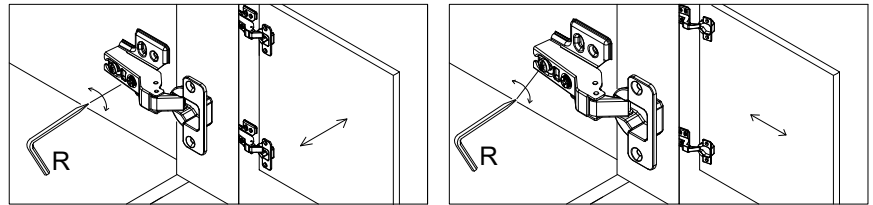

Step 23

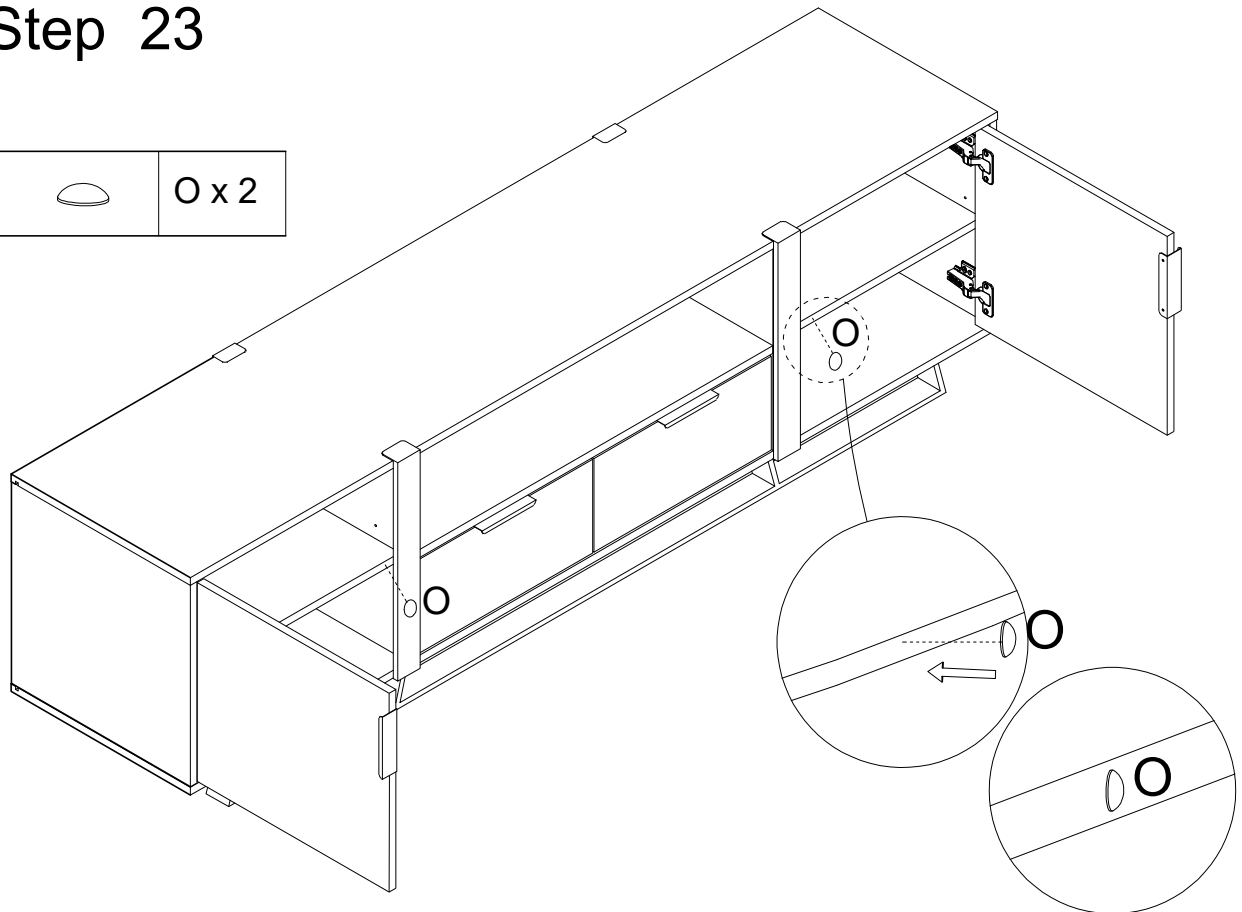
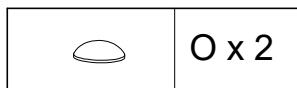



WARRANTY POLICY

1. Nothing in this Warranty affects the Consumer's rights under the Australian Consumer law. The benefits to the Consumer under this Warranty are in addition to the rights and remedies of the buyer under any Consumer Guarantees. The Australian Consumer Law requires that we confirm that:

Our goods come with guarantees that cannot be excluded under the Australian Consumer Law. You are entitled to a replacement or refund for a major failure and for compensation for any other reasonably foreseeable loss or damage. You are also entitled to have the goods repaired or replaced if the goods fail to be of acceptable quality.

2. Subject to Clause 1, the Seller warrants that **CRITERION** branded products will be free of manufacturing defects and will perform to the Seller's specifications subject to the following clauses.

3. The benefit of this 12 Month Warranty extends only to the owner of the property in which the Products manufactured or supplied by the Seller are installed and used by the owner for the duration of the Warranty Period.

4. If within the Warranty Period a manufacturing defect is discovered in the Product, or the Product fails to perform to the Seller's specifications as a result of some defect in material or workmanship, then the Seller will replace or repair the goods under Warranty or refund the purchase price paid by the consumer (except if the failure is a major failure)

5. The Warranty does not apply to Product that:

- a.) Has failed due to excessive wear and tear beyond what is considered to be reasonable.
- b.) Has been misused or neglected.
- c.) Has been damaged accidentally or by acts of God including fire and flooding.
- d.) Has been used or operated contrary to operating or maintenance instructions.
- e.) Has been damaged in transit from the Sellers store to the buyer, either by the buyer or a third party authorised to act for the
- f.) Was incorrectly assembled or installed

6. In order to make a claim under the Warranty, the Owner must provide proof of purchase in all cases.

7. The seller will examine any returned Products and if the Seller determines that there is an apparent defect through no fault of the Owner, the Seller will:

- a.) Make note of the Owner's contact details including the Owner's telephone number which the owner can be contacted during business hours, postal address and e-mail add
- b.) Make note of the defects reported by the Owner.
- c.) Take back the defective goods from the owner and determine within a reasonable time through dialogue with the Seller whether the goods are defective.



Criterion

SURFACE CARE INSTRUCTIONS

A little care and attention will extend the life and good looks of your furniture. Take care when using materials which might spill, or be sharp or abrasive, on the surface of your furniture.

Normal Cleaning For normal cleaning use a soft, dry, clean cloth.

Glass Cleaning for Frosted Glass Do not use glass cleaner or solvent based cleaners on the surface of the glass that has the frosting effect on it.

Normal Glass Cleaning You may use normal glass cleaning products on all other types of glass. Use a soft non -abrasive cloth to remove light dust and finger prints.

Vinyl and Cloth Cleaning Under no circumstances should any abrasive materials be used on this surface, as it will result in unrepairable damage.

Do not use solvents, solvent based cleaners, scouring pads, steel wool, furniture wax or scrubbing brushes.

Only use a slightly damp, soft, clean cloth on this surface if cleaning is needed. Do not scrub.

CAUTION

As with all furniture, this unit should not be exposed to direct sunlight, extreme temperatures or moisture, as this can result in non-repairable damage.

Note: The sooner a spill or mark is cleaned, the easier it will be removed.

Customer Service

FOR ALL MISSING OR FAULTY PARTS:

PLEASE RE-CHECK YOUR PACKAGING TO ENSURE THAT PARTS ARE MISSING THEN CONTACT THE STORE YOU PURCHASED THE ITEM FROM.

THE STORE WILL NEED THE FOLLOWING INFORMATION.....

- COPY OF YOUR PURCHASE SLIP/RECEIPT
- MODEL NUMBER OF THE UNIT PURCHASED
- DESCRIPTION/PART NUMBER OF THE MISSING OR FAULTY PART
- QUANTITY OF THE PARTS NEEDED

If for whatever reason you cannot get in contact with the store, please get in contact with Criterion direct at <http://www.rvm.com.au/contact/>

Product of RVM Australia
11 Tamara Drive, COCKBURN CENTRAL
Perth, Western Australia 6164
PH: 08 9417 9944