



ASSEMBLY INSTRUCTIONS

MODEL : WM1688-ET

IMPORTANT NOTE :

- * PLACE ALL WOODEN PARTS ON A CLEAN AND SMOOTH SURFACE SUCH AS A RUG OR CARPET TO AVOID THE PARTS FROM BEING SCRATCHED.
- * BEFORE YOU BEGIN, KINDLY FOLLOW THE ASSEMBLY INSTRUCTIONS STEP BY STEP.

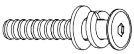
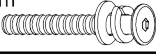
HARDWARE LIST

A	JCBC M6 x 35mm + S/W M6 + F/W M6 x 19mm 	6PCS
B	JCBC M6 x 50mm + S/W M6 + F/W M6 x 19mm 	2PCS
C	ALLEN KEY M4 (Ball Shape) 	1PC

PART LIST

1	TABLE TOP	1PC
2	TABLE LEG	1PC
3	BOTTOM LEG	1PC
4	LEG SUPPORT	1PC

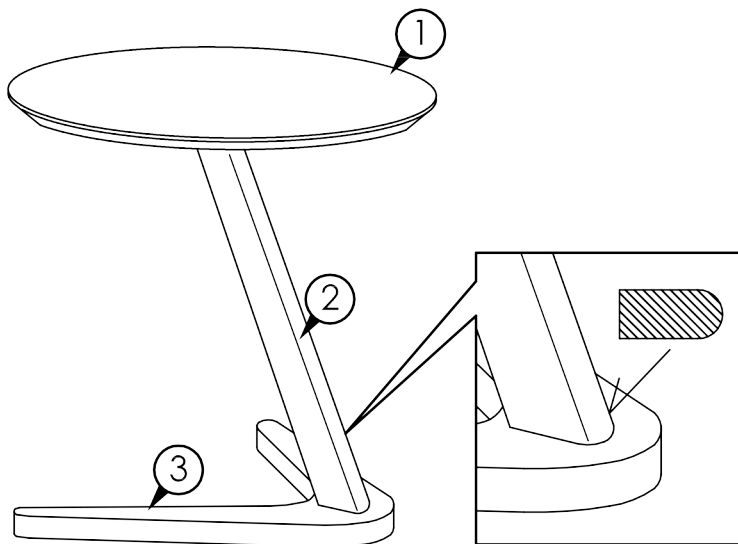

COMPLETED TABLE ASSEMBLY.

STEP 1

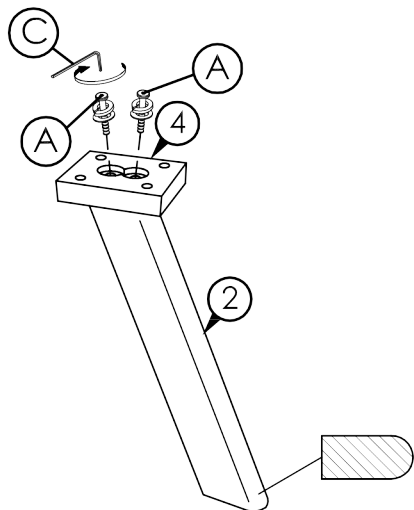

STEP 2

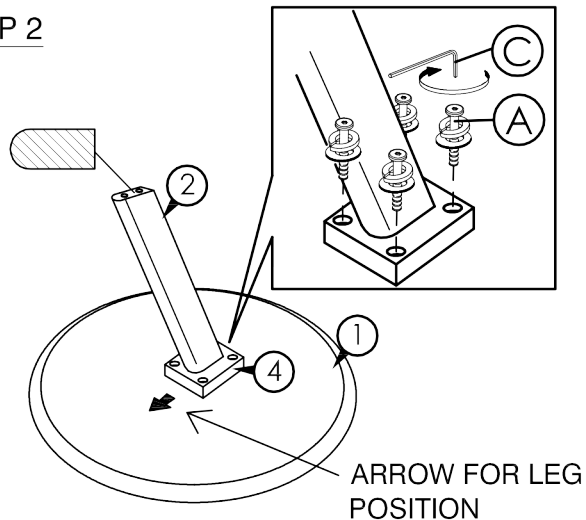

STEP 3

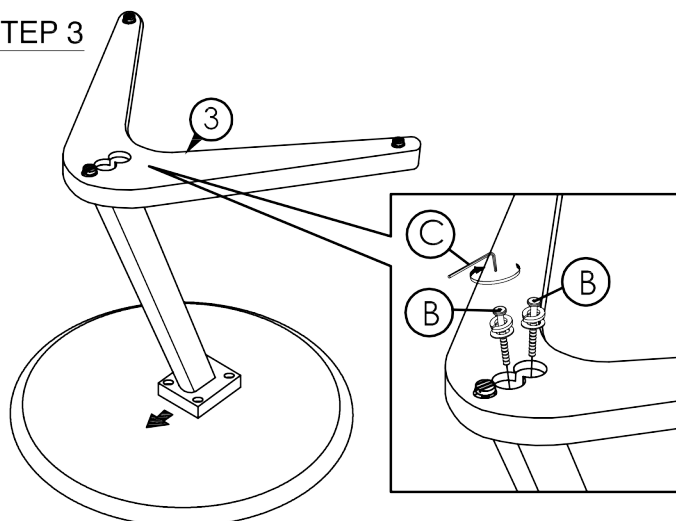

STEP 4

